

Customer Information Sheet

DRAWING No.: T1558-46

IF IN DOUBT - ASK

©

NOT TO SCALE

THIRD ANGLE PROJECTION

ALL DIMENSIONS IN mm

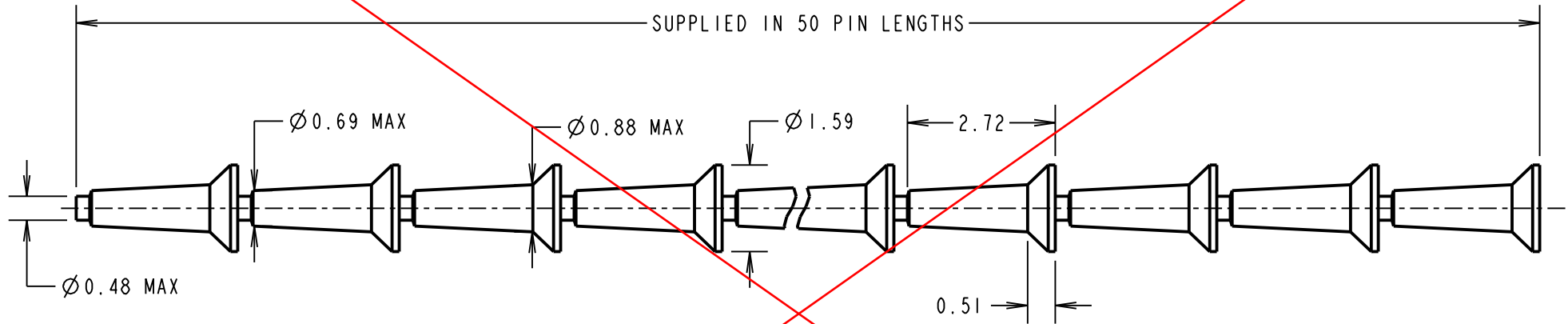

OBSOLETE

NOTES:

1. STRIPS ARE PACKED IN BOXES, 50 STRIPS PER BOX (QUANTITY 2500 PINS PER BOX).
2. USE WITH TRACK PIN INSERTION TOOL Z1002-00 AND INSTRUCTION SHEET IS-06.
3. THESE ITEMS ARE RoHS COMPLIANT.
4. RECOMMENDED MOUNTING HOLE SIZE = $\varnothing 0.83 +0.00/-0.03$ IN A 0.80mm THICK BOARD.

SM	9	22.02.11	11152
NAME	ISS.	DATE	C/NOTE
APPROVED: S. MCCULLAGH			
CHECKED: M. G. PLESTED			
DRAWN: J. PETERS			
CUSTOMER REF.:			
ASSEMBLY DRG:			

HARWIN

THIS DRAWING AND ANY INFORMATION OR DESCRIPTIVE MATTER SET OUT HEREON ARE CONFIDENTIAL AND COPYRIGHT PROPERTY OF THE HARWIN GROUP AND MUST NOT BE DISCLOSED, LOANED, COPIED OR USED FOR MANUFACTURING, TENDERING OR FOR ANY OTHER PURPOSE WITHOUT THEIR WRITTEN PERMISSION.

TOLERANCES

X. = ± 1 mm
 X.X = ± 0.25 mm
 X.XX = ± 0.10 mm
 X.XXX = ± 0.01 mm
 ANGLES = $\pm 5^\circ$
 UNLESS STATED

MATERIAL:

BRASS CW614N M (CuZn39Pb3)
 TO BS EN 12164:1998

FINISH: 100% TIN OVER NICKEL

S/AREA: mm²

TITLE:

CONTINUOUS TRACK PIN

DRAWING NUMBER:

T1558-46

SHT

2 OF 2

HARWIN USA
 TEL: 603 893 5376
 FAX: 603 893 5396
 mis@harwin.com

HARWIN Europe (UK)
 TEL: 023 9231 4545
 FAX: 023 9231 4590
 mis@harwin.co.uk

HARWIN Asia
 TEL: +65 6 779 4909
 FAX: +65 6 779 3868
 mis@harwin.com.sg