

# Customer Information Sheet

DRAWING No.: M80-5L20222M5-00-000-08-334

SHEET 2 OF 2

IF IN DOUBT - ASK

©

NOT TO SCALE

THIRD ANGLE PROJECTION

ALL DIMENSIONS IN mm

## SPECIFICATIONS:

**MATERIAL:**  
 MOULDING: GLASS FILLED PPS, UL94V-0, BLACK  
 SIGNAL CONTACT: PHOSPHOR BRONZE  
 POWER CONTACT: COPPER ALLOY  
 BOARD-MOUNT JACKSCREW, SCREW: STAINLESS STEEL

**FINISH:**  
 SIGNAL CONTACT:  
 0.75µ GOLD ON CONTACT AREA,  
 3µ 90/10 TIN/LEAD ON TAILS  
 POWER CONTACT: GOLD

**ELECTRICAL:**  
 WORKING VOLTAGE = 800V AC/DC  
 VOLTAGE PROOF = 1200V AC/DC  
 INSULATION RESISTANCE = 100MΩ MIN

**SIGNAL CONTACT:**  
 CURRENT RATING AT 25°C = 3.0A MAX  
 CURRENT RATING AT 85°C = 2.2A MAX  
 CONTACT RESISTANCE = 25mΩ MAX

**POWER CONTACT:**  
 CONTACT RESISTANCE = 6mΩ MAX  
 CURRENT RATING = 20A MAX

**MECHANICAL:**  
 DURABILITY = 500 OPERATIONS

**SIGNAL CONTACT:**  
 INSERTION FORCE = 2.0N MAX  
 WITHDRAWAL FORCE = 0.2N MIN

**POWER CONTACT:**  
 INSERTION FORCE = 8N MAX  
 WITHDRAWAL FORCE = 0.5N MIN

**ENVIRONMENTAL:**  
 TEMPERATURE RANGE = -55°C TO +125°C

**PACKING:**  
 TUBE

FOR COMPLETE SPECIFICATION SEE COMPONENT SPECIFICATION C005XX (LATEST ISSUE)

NOTES:  
 1. CONNECTORS ARE SUPPLIED WITH SCREWS LOOSE.

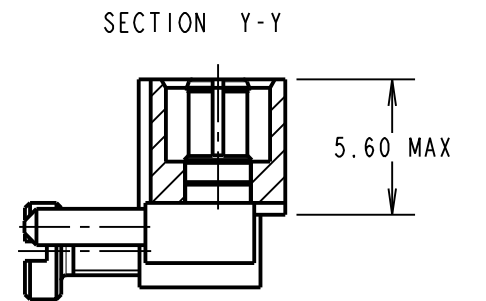
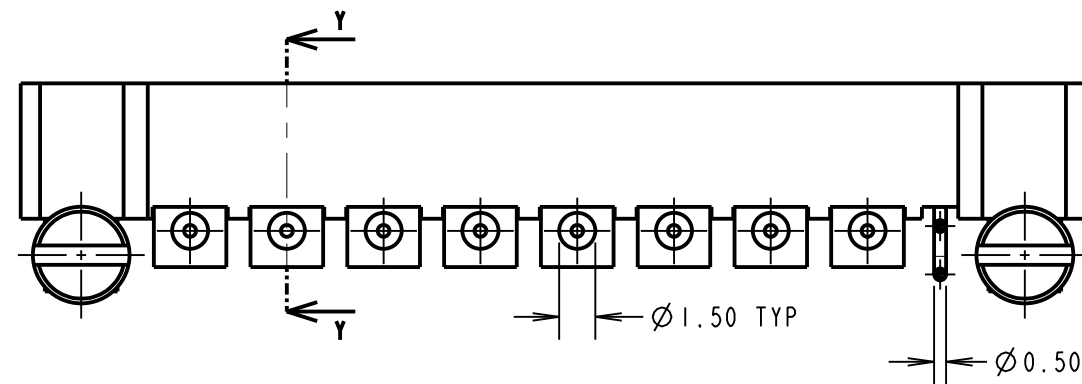
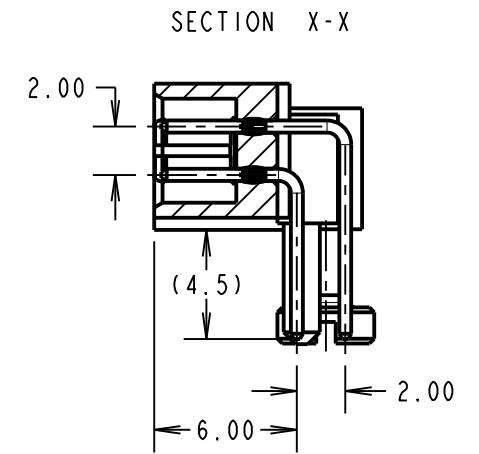
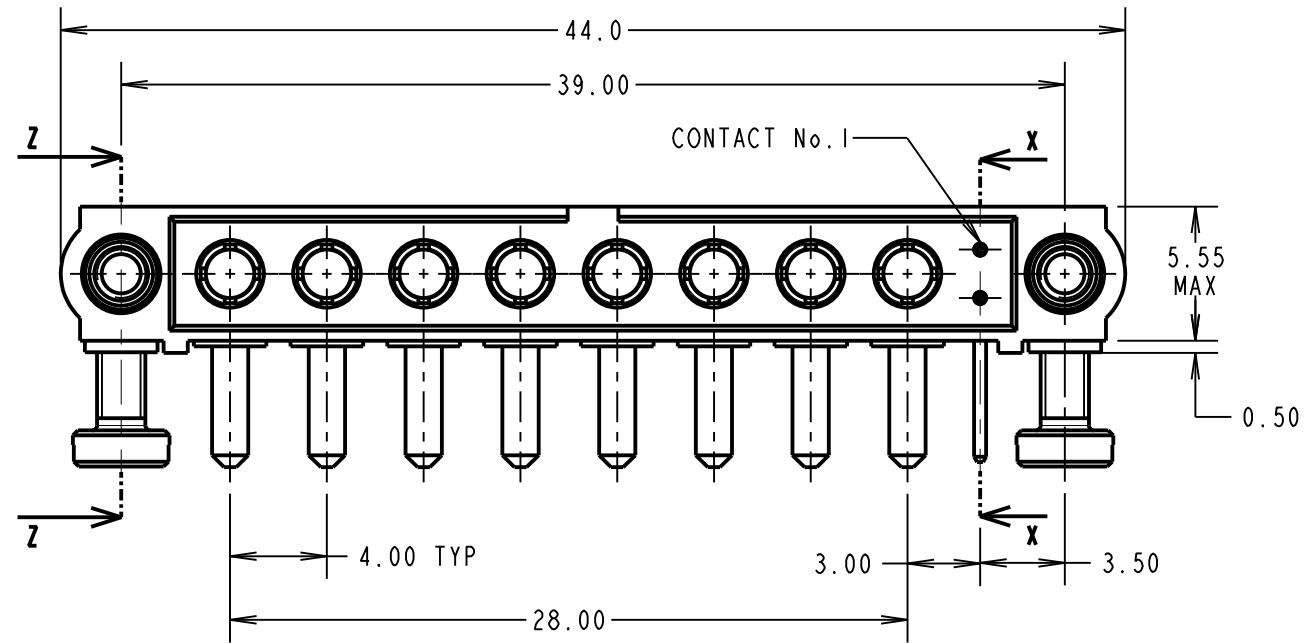
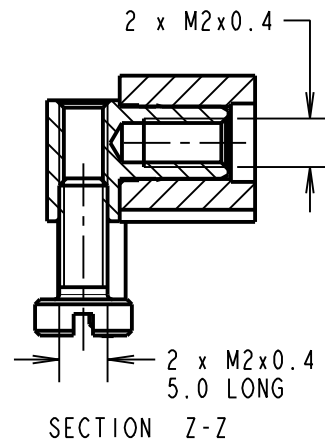

## RECOMMENDED PCB LAYOUT

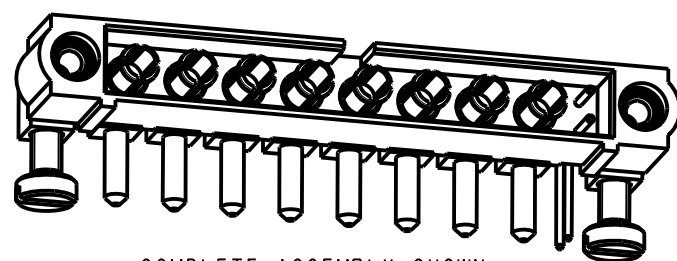
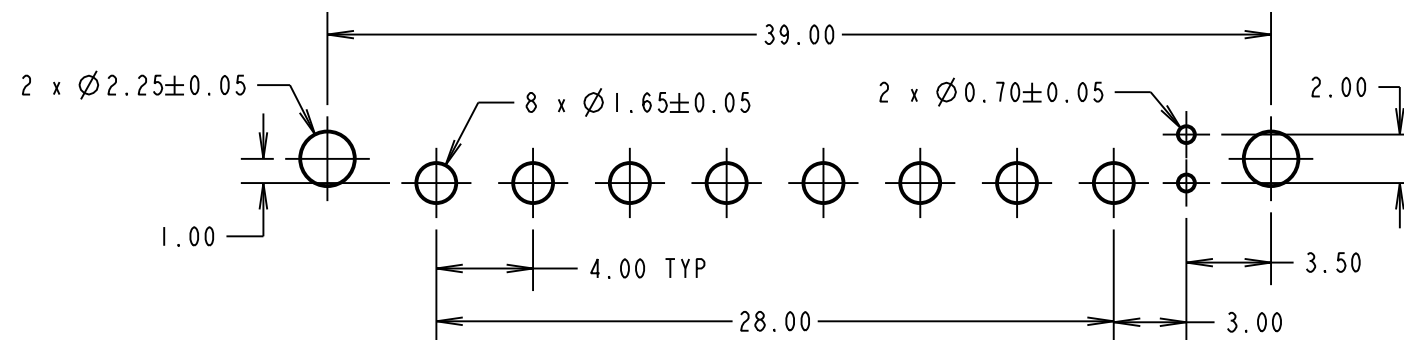

COMPLETE ASSEMBLY SHOWN FOR ILLUSTRATION ONLY

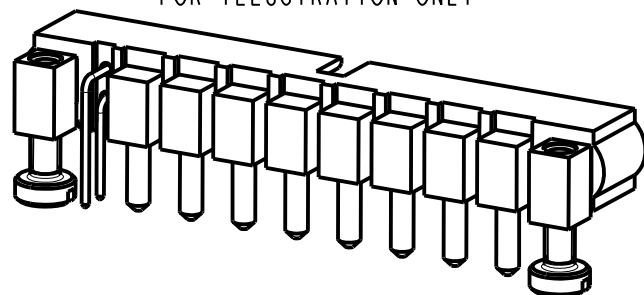

LS	2	30.10.17	13269
NAME	ISS.	DATE	C/NOTE
APPROVED: LS			
CHECKED: SB			
DRAWN: M. G. PLESTED			
CUSTOMER REF.:			
ASSEMBLY DRG:			

**HARWIN**

www.harwin.com  
 technical@harwin.com

THIS DRAWING AND ANY INFORMATION OR DESCRIPTIVE MATTER SET OUT HEREON ARE CONFIDENTIAL AND COPYRIGHT PROPERTY OF THE HARWIN GROUP AND MUST NOT BE DISCLOSED, LOANED, COPIED OR USED FOR MANUFACTURING, TENDERING OR FOR ANY OTHER PURPOSE WITHOUT THEIR WRITTEN PERMISSION.

**TOLERANCES**  
 X. = ±1mm  
 X.X = ±0.50mm  
 X.XX = ±0.10mm  
 X.XXX = ±0.01mm  
 ANGLES = ±5°  
 UNLESS STATED

**MATERIAL:**

SEE ABOVE

**FINISH:**

SEE ABOVE

**S/AREA:**

mm<sup>2</sup>

**TITLE:** JACKSCREW DATAMATE MIXED TECHNOLOGY PC TAIL MALE ASSEMBLY

**DRAWING NUMBER:**

**M80-5L20222M5-00-000-08-334**

SHT 2 OF 2