

Customer Information Sheet

DRAWING No.: M80-5D12205MI-05-335-00-000

SHEET 2 OF 2

IF IN DOUBT - ASK

©

NOT TO SCALE

THIRD ANGLE PROJECTION

ALL DIMENSIONS IN mm

SPECIFICATIONS:

MATERIAL:
 MOULDING: GLASS FILLED PPS, UL94V-0, BLACK
 SIGNAL CONTACT: BRASS
 POWER CONTACT:
 BODY = COPPER ALLOY
 LATCHING COLLAR = BERYLLIUM COPPER
 JACKSCREW: STAINLESS STEEL

FINISH:
 SIGNAL CONTACT: 0.25 - 0.30µ GOLD
 POWER CONTACT:
 BODY = GOLD
 LATCHING COLLAR = NICKEL

ELECTRICAL:
 WORKING VOLTAGE = 120V AC/DC
 VOLTAGE PROOF = 360V AC/DC
 INSULATION RESISTANCE = 100MΩ MIN
 SIGNAL CONTACT:
 CURRENT RATING AT 25°C = 3.0A MAX
 CURRENT RATING AT 85°C = 2.2A MAX
 CONTACT RESISTANCE = 25 mΩ MAX
 POWER CONTACT:
 CONTACT RESISTANCE 6 mΩ MAX
 CURRENT RATING = 20A MAX WITH 12AWG
 CONTACT AS SPECIFIED

MECHANICAL:
 DURABILITY = 500 OPERATIONS
 SIGNAL CONTACT:
 INSERTION FORCE = 2.8N MAX
 WITHDRAWAL FORCE = 0.2N MIN
 POWER CONTACT:
 INSERTION FORCE = 5N MAX
 WITHDRAWAL FORCE = 0.5N MIN

ENVIRONMENTAL:
 TEMPERATURE RANGE = -55°C TO +125°C

PACKING:
 BAG
 FOR COMPLETE SPECIFICATION SEE COMPONENT SPECIFICATION C005XX (LATEST ISSUE)

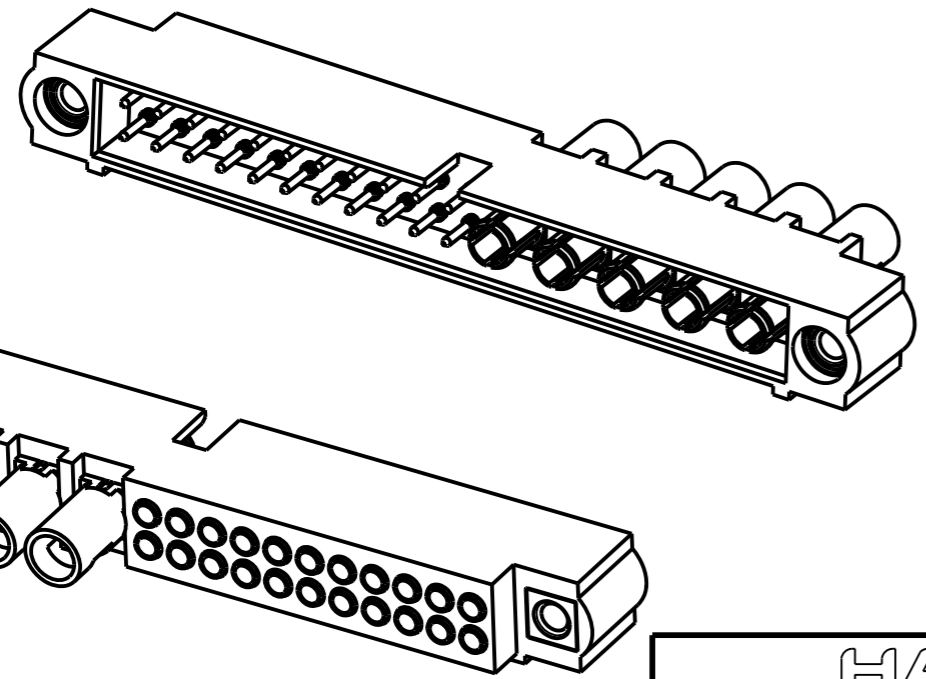
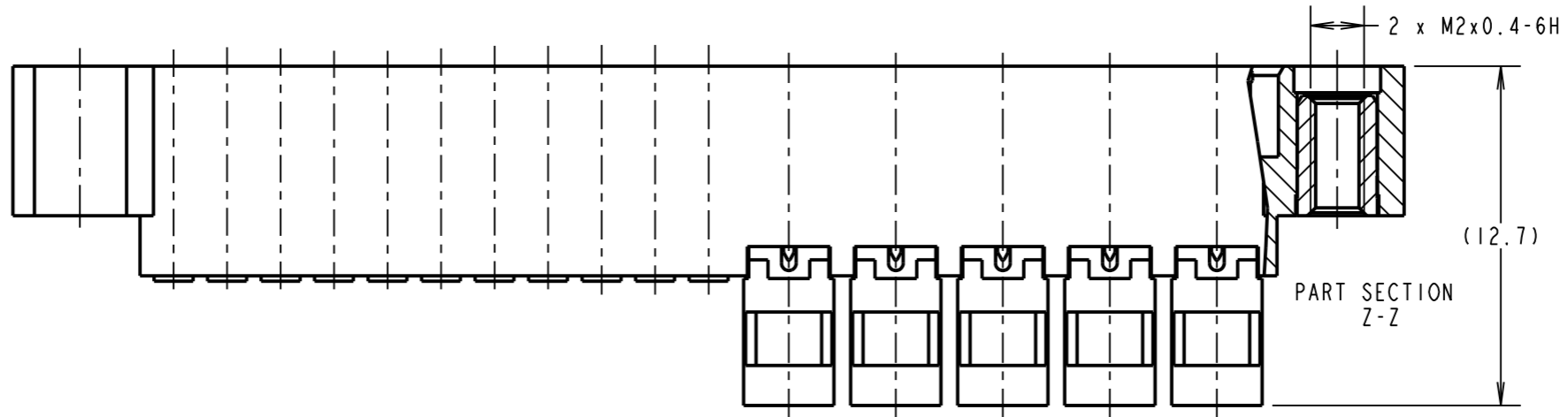
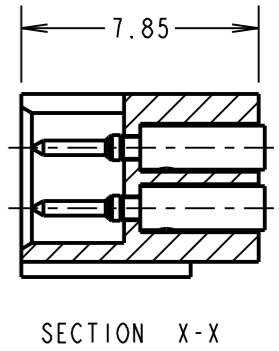
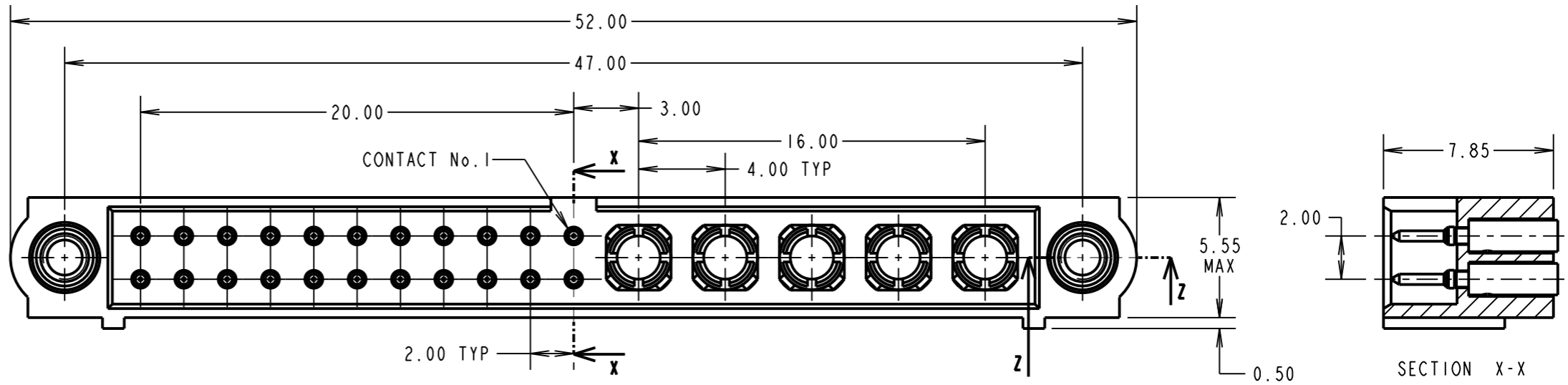

NOTES:

- CONNECTORS ARE SUPPLIED WITH CONTACTS LOOSE.
- FOR EXTRA SIGNAL CONTACTS, USE PART NUMBER M80-1940005.
- RECOMMENDED SIGNAL WIRE TYPE = BS 3G 210 TYPE A, PTFE INSULATED 22 AWG. MAX INSULATION DIAMETER = Ø1.10mm. STRIP WIRE BY 2.00MM FOR CRIMPING.
- RECOMMENDED HAND CRIMP TOOL FOR SIGNAL CONTACTS = M22520/2-01 WITH POSITIONER Z80-193.
- SIGNAL CONTACT INSERTION AND EXTRACTION TOOL = Z80-280.
- FOR EXTRA POWER CONTACTS, USE PART NUMBER M80-335
- POWER CONTACT WIRE, STRIP BY 5.00mm MINIMUM
- POWER CONTACT EXTRACTION TOOL = Z80-290
- INSTRUCTION SHEETS ARE AVAILABLE.

SM	1	30.11.10	10806
NAME	ISS.	DATE	C/NOTE
APPROVED: S. MCCULLAGH			
CHECKED: R. ADDE			
DRAWN: R. ADDE			
CUSTOMER REF.:			
ASSEMBLY DRG:			

HARWIN			THIS DRAWING AND ANY INFORMATION OR DESCRIPTIVE MATTER SET OUT HEREON ARE CONFIDENTIAL AND COPYRIGHT PROPERTY OF THE HARWIN GROUP AND MUST NOT BE DISCLOSED, LOANED, COPIED OR USED FOR MANUFACTURING, TENDERING OR FOR ANY OTHER PURPOSE WITHOUT THEIR WRITTEN PERMISSION.	TOLERANCES X. = ±1mm X.X = ±0.25mm X.XX = ±0.10mm X.XXX = ±0.01mm ANGLES = ±5° UNLESS STATED	MATERIAL: SEE ABOVE FINISH: SEE ABOVE S/AREA: mm ²	TITLE: JACKSCREW DATAMATE MIXED TECHNOLOGY VERTICAL CRIMP MALE ASSEMBLY DRAWING NUMBER: M80-5D12205MI-05-335-00-000	SHT 2 OF 2
HARWIN USA TEL: 603 893 5376 FAX: 603 893 5396 mis@harwin.com	HARWIN Europe (UK) TEL: 023 9231 4545 FAX: 023 9231 4590 mis@harwin.co.uk	HARWIN Asia TEL: +65 6 779 4909 FAX: +65 6 779 3868 mis@harwin.com.sg					