

# Customer Information Sheet

DRAWING No.: M80-4D11405F2-01-327-01-327

SHEET 2 OF 2

IF IN DOUBT - ASK

Ⓒ

NOT TO SCALE

THIRD ANGLE PROJECTION

ALL DIMENSIONS IN mm

## SPECIFICATIONS:

### MATERIAL:

MOULDING: GLASS FILLED PPS, UL94V-0, BLACK

### SIGNAL CONTACT:

CLIP = BERYLLIUM COPPER  
SHELL = BRASS

### POWER CONTACT:

BODY = COPPER ALLOY  
LATCHING COLLAR = BERYLLIUM COPPER  
JACKSCREW, CIRCLIP: STAINLESS STEEL

### FINISH:

#### SIGNAL CONTACT:

CLIP = 0.3µ GOLD  
SHELL = 0.25-0.3µ GOLD

#### POWER CONTACT:

BODY = GOLD  
LATCHING COLLAR = NICKEL

### ELECTRICAL:

WORKING VOLTAGE = 120V AC/DC

VOLTAGE PROOF = 360V AC/DC

INSULATION RESISTANCE = 100MΩ MIN

#### SIGNAL CONTACT:

CURRENT RATING AT 25°C = 3.0A MAX  
CURRENT RATING AT 85°C = 2.2A MAX  
CONTACT RESISTANCE = 25 mΩ MAX

#### POWER CONTACT:

CONTACT RESISTANCE = 6 mΩ MAX  
CURRENT RATING = 10A MAX WITH 16AWG CONTACT AS SPECIFIED

### MECHANICAL:

DURABILITY = 500 OPERATIONS

#### SIGNAL CONTACT:

INSERTION FORCE = 2.8N MAX  
WITHDRAWAL FORCE = 0.2N MIN

#### POWER CONTACT:

INSERTION FORCE = 5N MAX  
WITHDRAWAL FORCE = 0.5N MIN

### ENVIRONMENTAL:

TEMPERATURE RANGE = -55°C TO +125°C

### PACKING:

BAG

FOR COMPLETE SPECIFICATION SEE COMPONENT SPECIFICATION C005XX (LATEST ISSUE)

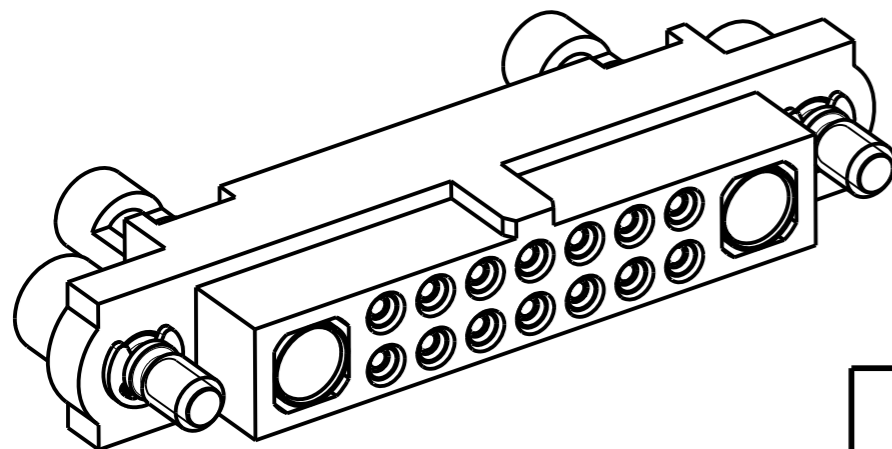
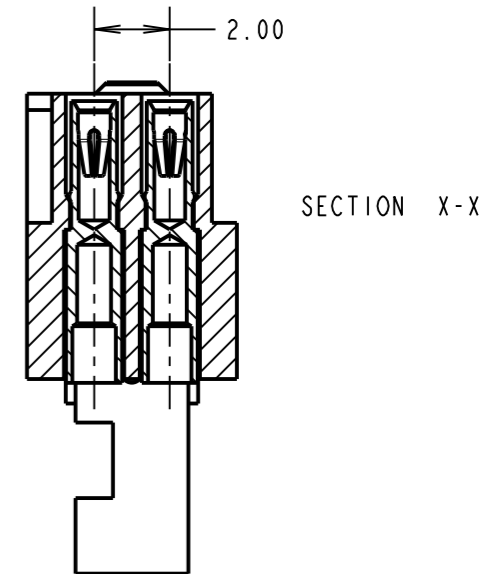
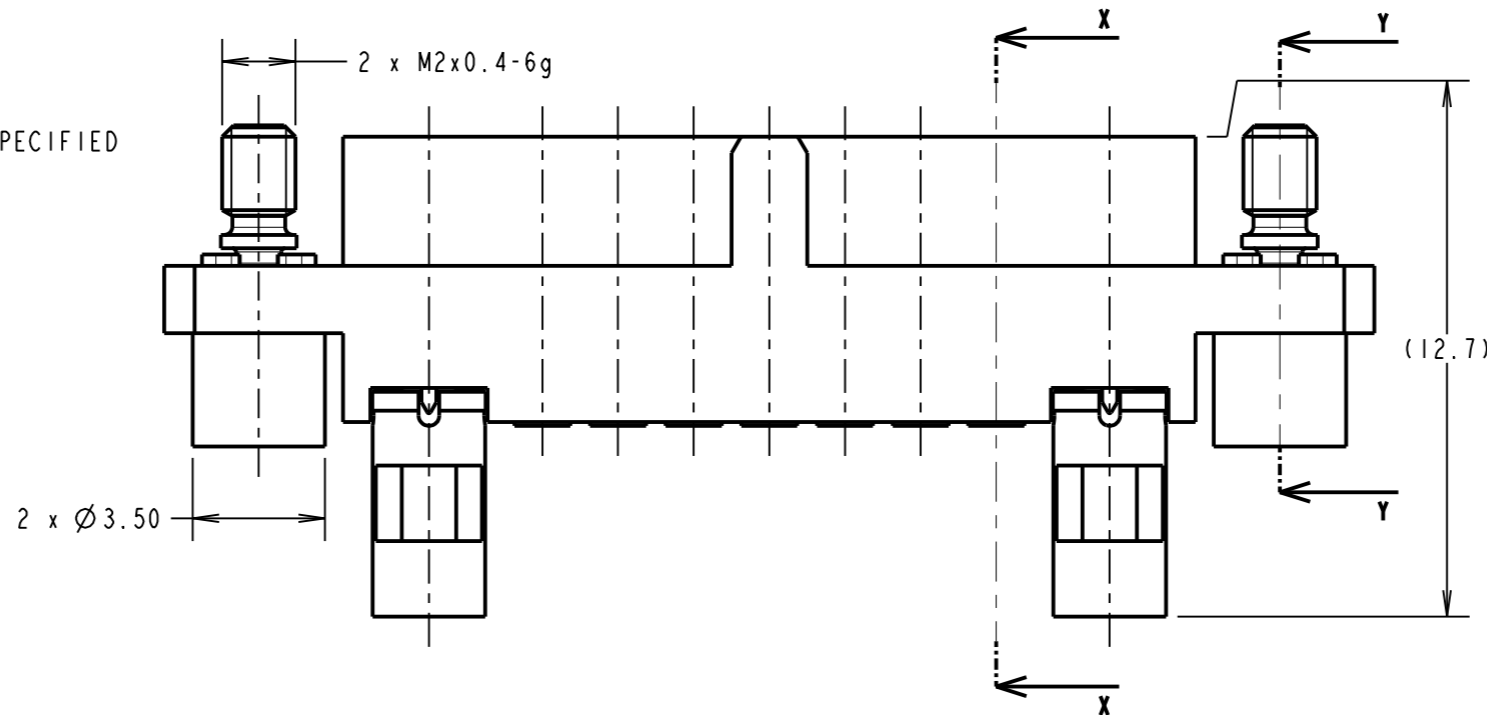
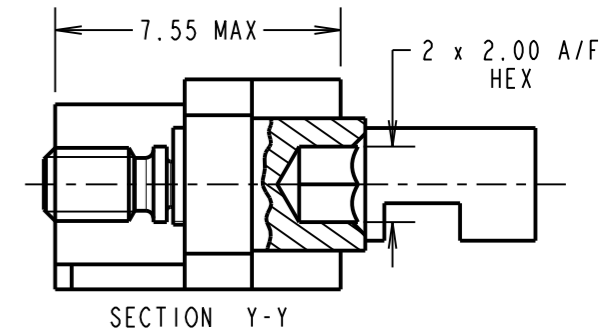
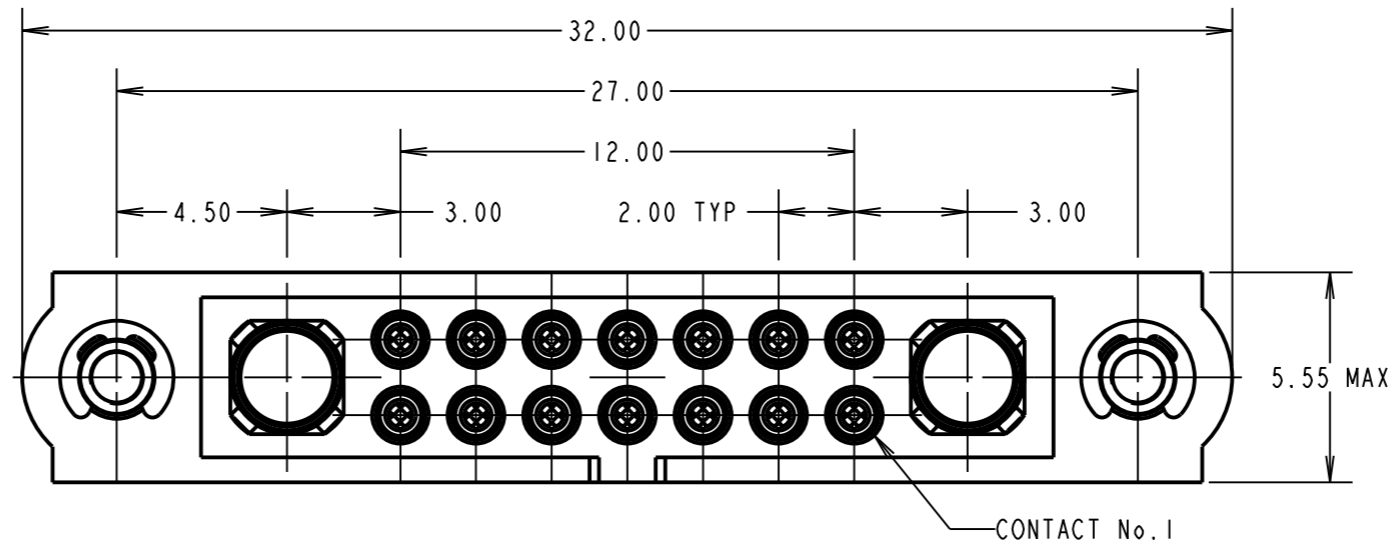

### NOTES:

- CONNECTORS ARE SUPPLIED WITH CONTACTS LOOSE.
- FOR EXTRA SIGNAL CONTACTS, USE PART NUMBER M80-0110005.
- RECOMMENDED SIGNAL WIRE TYPE = BS 3G 210 TYPE A, PTFE INSULATED 22 AWG. MAX INSULATION DIAMETER = Ø1.10mm. STRIP WIRE BY 2.00MM FOR CRIMPING.
- RECOMMENDED HAND CRIMP TOOL FOR SIGNAL CONTACTS = M22520/2-01 WITH POSITIONER T5747.
- SIGNAL CONTACT INSERTION AND EXTRACTION TOOL = Z80-280.
- FOR EXTRA POWER CONTACTS, USE PART NUMBER M80-327.
- POWER CONTACT WIRE, STRIP BY 5.00mm MINIMUM.
- POWER CONTACT EXTRACTION TOOL = Z80-290.
- INSTRUCTION SHEETS ARE AVAILABLE.

SF	1	25.10.10	----
NAME	ISS.	DATE	C/NOTE
APPROVED: S.FLOWER			
CHECKED: W.J.BOURNE			
DRAWN: S.FLOWER			
CUSTOMER REF.:			
ASSEMBLY DRG:			

## HARWIN

HARWIN USA TEL: 603 893 5376 FAX: 603 893 5396 mis@harwin.com	HARWIN Europe (UK) TEL: 023 9231 4545 FAX: 023 9231 4590 mis@harwin.co.uk	HARWIN Asia TEL: +65 6 779 4909 FAX: +65 6 779 3868 mis@harwin.com.sg
--	--	--

THIS DRAWING AND ANY INFORMATION OR DESCRIPTIVE MATTER SET OUT HEREON ARE CONFIDENTIAL AND COPYRIGHT PROPERTY OF THE HARWIN GROUP AND MUST NOT BE DISCLOSED, LOANED, COPIED OR USED FOR MANUFACTURING, TENDERING OR FOR ANY OTHER PURPOSE WITHOUT THEIR WRITTEN PERMISSION.

TOLERANCES  
X. = ±1mm  
X.X = ±0.25mm  
X.XX = ±0.10mm  
X.XXX = ±0.01mm  
ANGLES = ±5°  
UNLESS STATED

MATERIAL:

SEE ABOVE

FINISH:

SEE ABOVE

S/AREA:

mm<sup>2</sup>

TITLE: JACKSCREW DATAMATE MIXED TECHNOLOGY SOLDER FEMALE ASSEMBLY

DRAWING NUMBER:

**M80-4D11405F2-01-327-01-327**

SHT  
2 OF 2