

Customer Information Sheet

DRAWING No.: M80-4D11005F1-01-309-00-000

SHEET 2 OF 2

IF IN DOUBT - ASK

©

NOT TO SCALE

THIRD ANGLE PROJECTION

ALL DIMENSIONS IN mm

SPECIFICATIONS:

MATERIAL:

MOULDING: GLASS FILLED PPS, UL94V-0, BLACK

SIGNAL CONTACT:

CLIP = BERYLIUM COPPER

SHELL = COPPER ALLOY

COAX CONTACT:

BODY, SLEEVE, END PLUG = COPPER ALLOY

INNER CONTACT, LATCHING COLLAR = BERYLIUM COPPER

INSULATORS = PTFE

JACKSCREW, CIRCLIP: STAINLESS STEEL

FINISH:

SIGNAL CONTACT:

CLIP = 0.3µ GOLD OVER NICKEL

SHELL = 0.25-0.3µ GOLD OVER NICKEL

COAX CONTACT:

BODY, SLEEVE, INNER CONTACT = GOLD OVER NICKEL

LATCHING COLLAR = NICKEL

ELECTRICAL:

WORKING VOLTAGE = 800V AC/DC

VOLTAGE PROOF = 1200V AC/DC

INSULATION RESISTANCE = 100MΩ MIN

SIGNAL CONTACT:

CURRENT RATING AT 25°C = 3.0A MAX

CURRENT RATING AT 85°C = 2.2A MAX

CONTACT RESISTANCE = 25mΩ MAX

COAX CONTACT:

FREQUENCY RANGE = 6GHz

IMPEDANCE = 50Ω

V.S.W.R = 1.05 + (0.04 x FREQUENCY) GHz MAX

CONTACT RESISTANCE = 6mΩ MAX

INSULATION RESISTANCE = 10⁶MΩ @250V AC

OPERATING VOLTAGE = 180V AC @ 500mA

MAXIMUM VOLTAGE = 1000V AC

MECHANICAL:

DURABILITY = 500 OPERATIONS

SIGNAL CONTACT:

INSERTION FORCE = 2.0N MAX

WITHDRAWAL FORCE = 0.2N MIN

COAX CONTACT:

INSERTION FORCE = 8N MAX

WITHDRAWAL FORCE = 0.5N MIN

ENVIRONMENTAL:

TEMPERATURE RANGE = -55°C TO +125°C

PACKING:

BAG

FOR COMPLETE SPECIFICATION SEE COMPONENT SPECIFICATION C005XX (LATEST ISSUE)

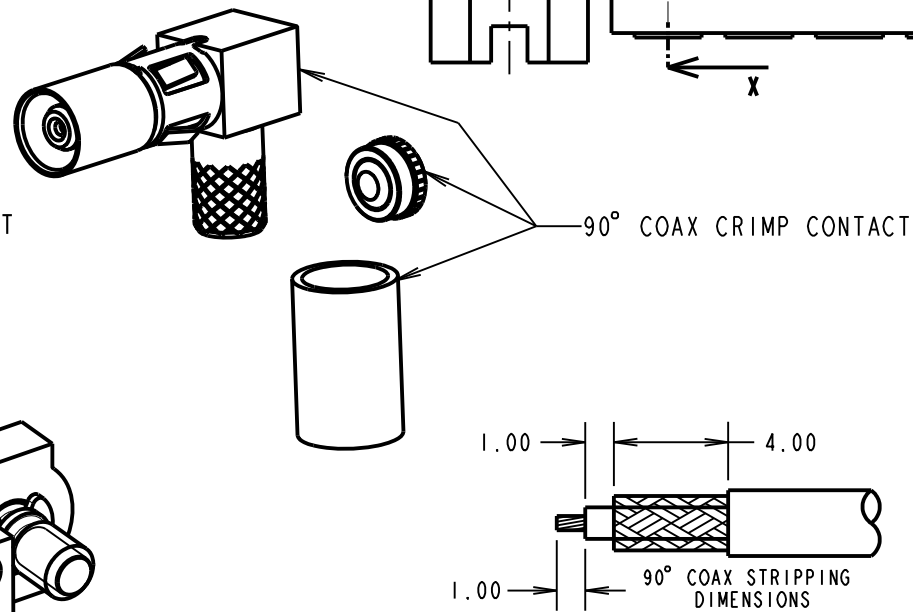
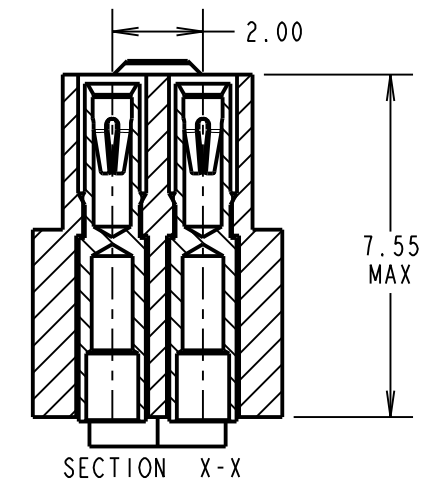
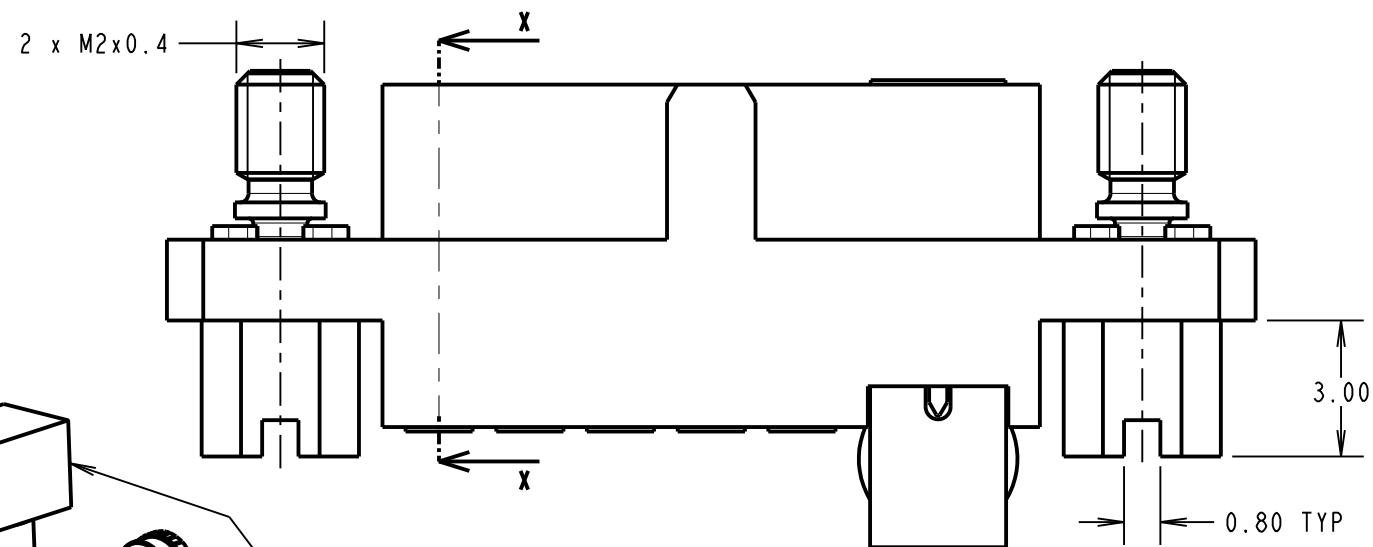
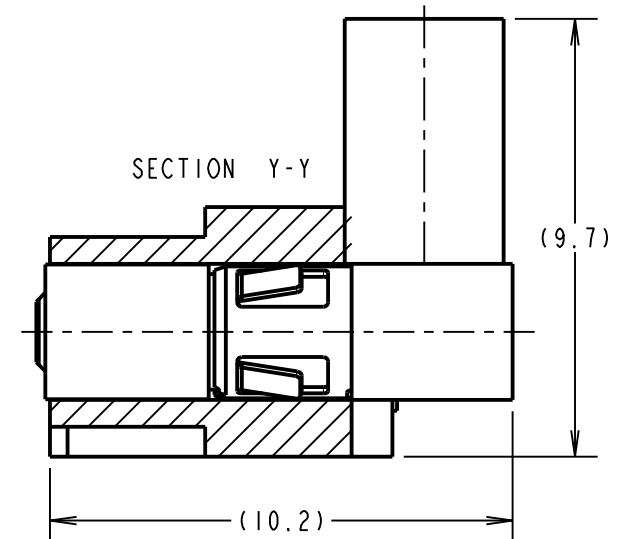
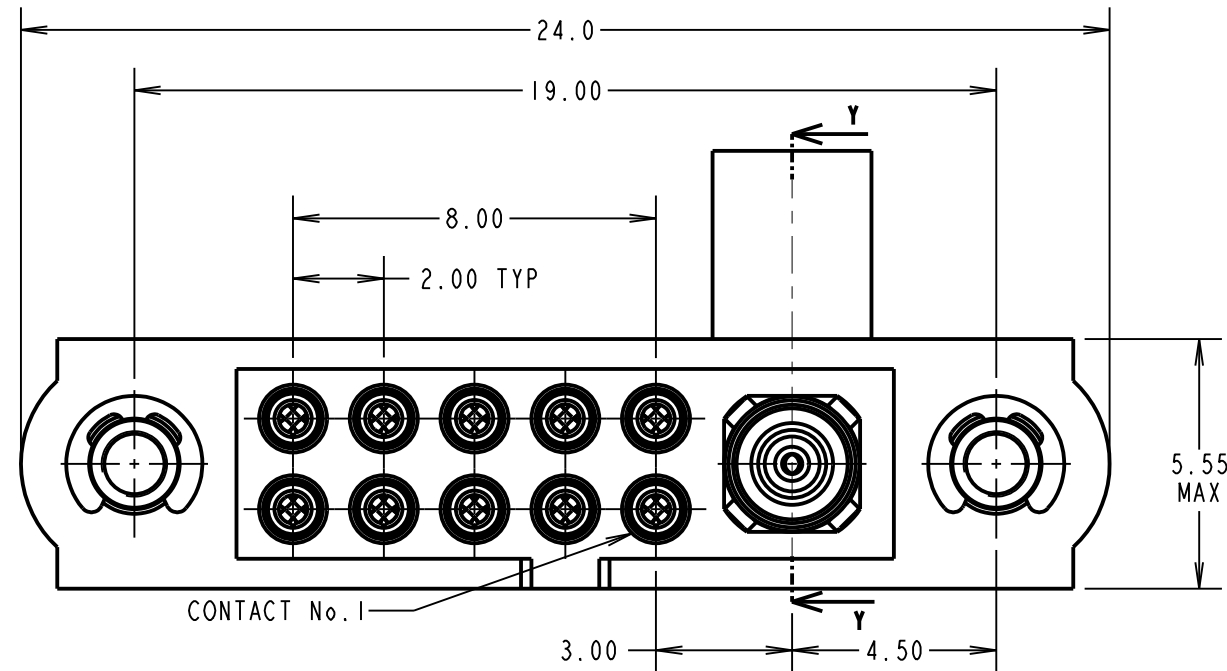

NOTES:

- CONNECTORS ARE SUPPLIED WITH CONTACTS LOOSE.
- FOR EXTRA SIGNAL CONTACTS, USE PART NUMBER M80-0110005.
- RECOMMENDED SIGNAL WIRE TYPE = BS 3G 210 TYPE A, PTFE INSULATED 22 AWG. MAX INSULATION DIAMETER = Ø1.10mm. STRIP WIRE BY 2.00mm FOR CRIMPING.
- RECOMMENDED HAND CRIMP TOOL FOR SIGNAL CONTACTS = M22520/2-01 WITH POSITIONER T5747. REFER TO TOOLING INSTRUCTION SHEET IS-01 FOR COMPLETE CRIMPING INSTRUCTIONS.
- SIGNAL CONTACT INSERTION AND EXTRACTION TOOL = Z80-280. REFER TO TOOLING INSTRUCTION SHEET IS-25 FOR ASSEMBLY INSTRUCTIONS.
- COAX CONTACT IS SUPPLIED AS A KIT OF PARTS: BODY, MAIN INSULATOR, INNER CONTACT AND LATCHING COLLAR ARE PRE-ASSEMBLED AND SLEEVE AND INSULATED END PLUG ASSEMBLY ARE SEPARATE.
- FOR EXTRA COAX CONTACTS, USE PART NUMBER M80-309.
- COAX CONTACT EXTRACTION TOOL = Z80-290.
- INSTRUCTION SHEETS ARE AVAILABLE.

MSP	1	31.05.17	----
NAME	ISS.	DATE	C/NOTE
APPROVED: M.PERREN			
CHECKED: S.BENNETT			
DRAWN: M.PERREN			
CUSTOMER REF.:			
ASSEMBLY DRG:			

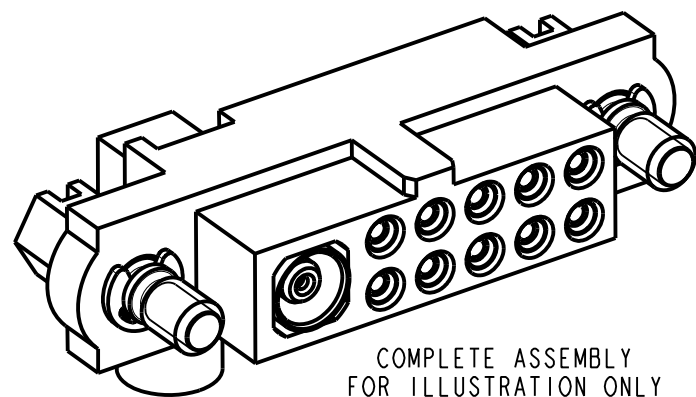

HARWIN

www.harwin.com
technical@harwin.com

THIS DRAWING AND ANY INFORMATION OR DESCRIPTIVE MATTER SET OUT HEREON ARE CONFIDENTIAL AND COPYRIGHT PROPERTY OF THE HARWIN GROUP AND MUST NOT BE DISCLOSED, LOANED, COPIED OR USED FOR MANUFACTURING, TENDERING OR FOR ANY OTHER PURPOSE WITHOUT THEIR WRITTEN PERMISSION.

TOLERANCES

X. = ±1mm
X.X = ±0.25mm
X.XX = ±0.10mm
X.XXX = ±0.01mm
ANGLES = ±5°
UNLESS STATED

MATERIAL:

SEE ABOVE

FINISH:

SEE ABOVE

S/AREA:

mm²

TITLE: JACKSCREW DATAMATE MIXED TECHNOLOGY CRIMP FEMALE ASSEMBLY

DRAWING NUMBER:

M80-4D11005F1-01-309-00-000

SHT 2 OF 2