

Customer Information Sheet

DRAWING No.: M80-4D10205F2-08-325-00-000

SHEET 2 OF 2

IF IN DOUBT - ASK

©

NOT TO SCALE

THIRD ANGLE PROJECTION

ALL DIMENSIONS IN mm

SPECIFICATIONS:

MATERIAL:
 MOULDING: GLASS FILLED PPS, UL94V-0, BLACK
SIGNAL CONTACT:
 CLIP = BERYLLIUM COPPER
 SHELL = BRASS
POWER CONTACT:
 BODY = COPPER ALLOY
 LATCHING COLLAR = BERYLLIUM COPPER
 JACKSCREW, CIRCLIP: STAINLESS STEEL
FINISH:
SIGNAL CONTACT:
 CLIP = 0.3µ GOLD
 SHELL = 0.25-0.3µ GOLD
POWER CONTACT:
 BODY = GOLD
 LATCHING COLLAR = NICKEL
ELECTRICAL:
 WORKING VOLTAGE = 800V AC/DC
 VOLTAGE PROOF = 1200V AC/DC
 INSULATION RESISTANCE = 100MΩ MIN
SIGNAL CONTACT:
 CURRENT RATING AT 25°C = 3.0A MAX
 CURRENT RATING AT 85°C = 2.2A MAX
 CONTACT RESISTANCE = 25 mΩ MAX
POWER CONTACT:
 CONTACT RESISTANCE = 6 mΩ MAX
 CURRENT RATING = 20A MAX WITH 12AWG
 CONTACT AS SPECIFIED
MECHANICAL:
 DURABILITY = 500 OPERATIONS
SIGNAL CONTACT:
 INSERTION FORCE = 2.8N MAX
 WITHDRAWAL FORCE = 0.2N MIN
POWER CONTACT:
 INSERTION FORCE = 5N MAX
 WITHDRAWAL FORCE = 0.5N MIN
ENVIRONMENTAL:
 TEMPERATURE RANGE = -55°C TO +125°C
PACKING:
 BAG
 FOR COMPLETE SPECIFICATION SEE COMPONENT SPECIFICATION C005XX (LATEST ISSUE)

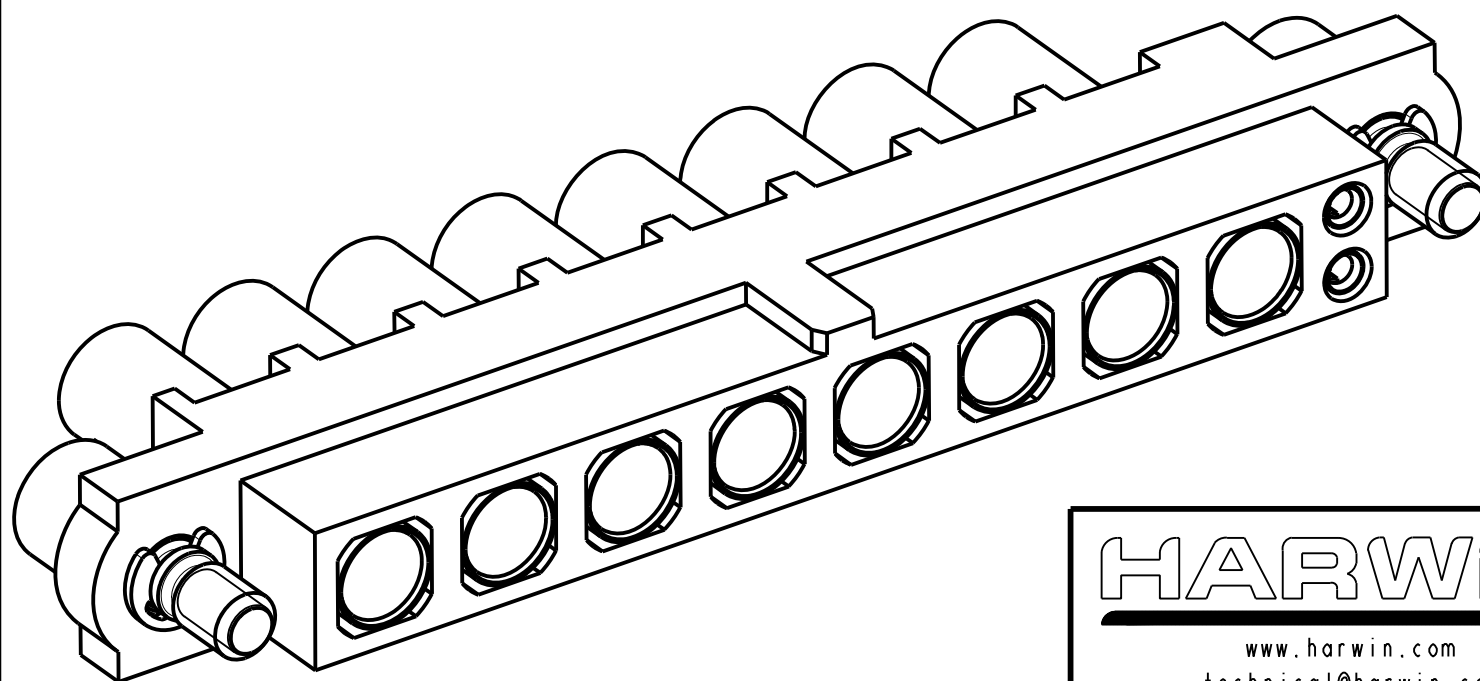
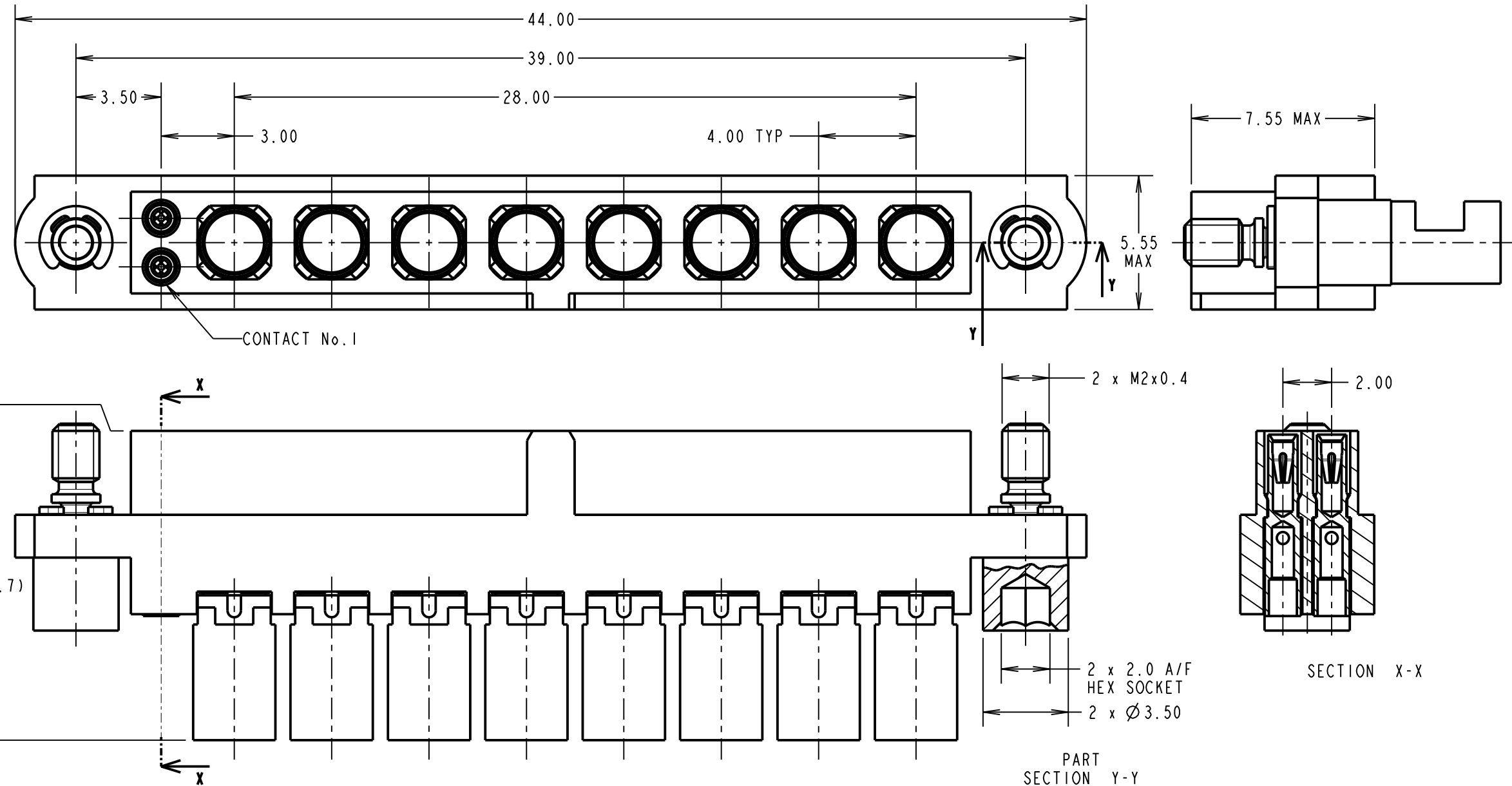

NOTES:

- CONNECTORS ARE SUPPLIED WITH CONTACTS LOOSE.
- FOR EXTRA SIGNAL CONTACTS, USE PART NUMBER M80-0110005.
- RECOMMENDED SIGNAL WIRE TYPE = BS 3G 210 TYPE A, PTFE INSULATED 22 AWG. MAX INSULATION DIAMETER = Ø1.10mm. STRIP WIRE BY 2.00mm FOR CRIMPING.
- RECOMMENDED HAND CRIMP TOOL FOR SIGNAL CONTACTS = M22520/2-01 WITH POSITIONER T5747.
- SIGNAL CONTACT INSERTION AND EXTRACTION TOOL = Z80-280.
- FOR EXTRA POWER CONTACTS, USE PART NUMBER M80-325.
- POWER CONTACT WIRE, STRIP BY 5.00mm MINIMUM.
- POWER CONTACT EXTRACTION TOOL = Z80-290.
- INSTRUCTION SHEETS ARE AVAILABLE.

| | | | |
|----------------------|------|----------|--------|
| MGP | 1 | 16.10.12 | ----- |
| NAME | ISS. | DATE | C/NOTE |
| APPROVED: MGP | | | |
| CHECKED: SB | | | |
| DRAWN: M. G. PLESTED | | | |
| CUSTOMER REF.: | | | |
| ASSEMBLY DRG: | | | |

HARWIN
 www.harwin.com
 technical@harwin.com

THIS DRAWING AND ANY INFORMATION OR DESCRIPTIVE MATTER SET OUT HEREON ARE CONFIDENTIAL AND COPYRIGHT PROPERTY OF THE HARWIN GROUP AND MUST NOT BE DISCLOSED, LOANED, COPIED OR USED FOR MANUFACTURING, TENDERING OR FOR ANY OTHER PURPOSE WITHOUT THEIR WRITTEN PERMISSION.

TOLERANCES
 X. = ±1mm
 X.X = ±0.25mm
 X.XX = ±0.10mm
 X.XXX = ±0.01mm
 ANGLES = ±5°
 UNLESS STATED

MATERIAL:
 SEE ABOVE
FINISH: SEE ABOVE
S/AREA: mm²

TITLE: JACKSCREW DATAMATE MIXED TECHNOLOGY CRIMP FEMALE ASSEMBLY
DRAWING NUMBER: M80-4D10205F2-08-325-00-000
 SHT 2 OF 2