

Customer Information Sheet

DRAWING No.: M40-600XX46

SHEET 2 OF 2

IF IN DOUBT - ASK

©

NOT TO SCALE

THIRD ANGLE PROJECTION

ALL DIMENSIONS IN mm

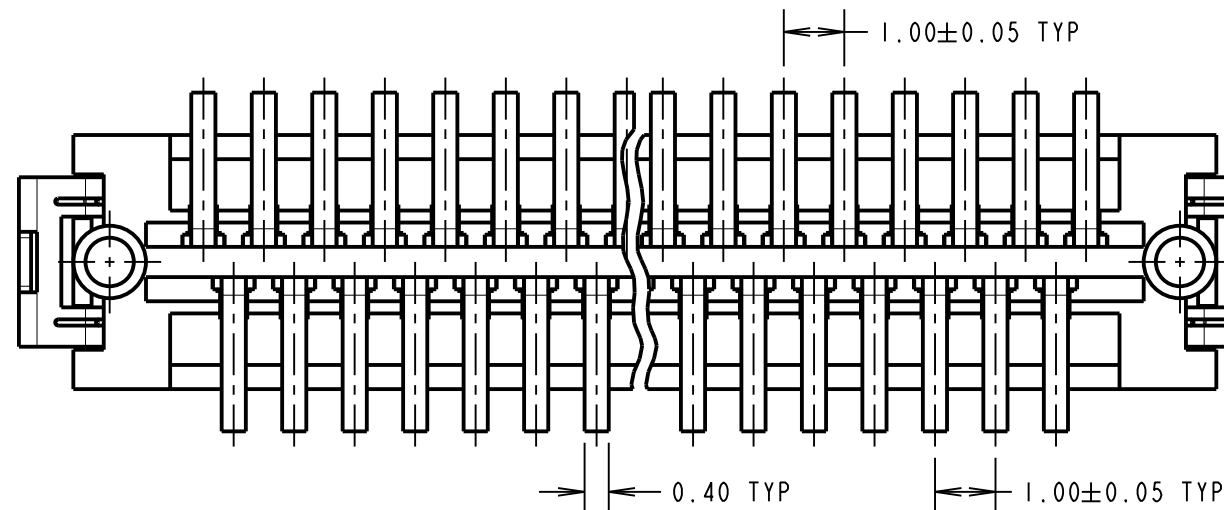
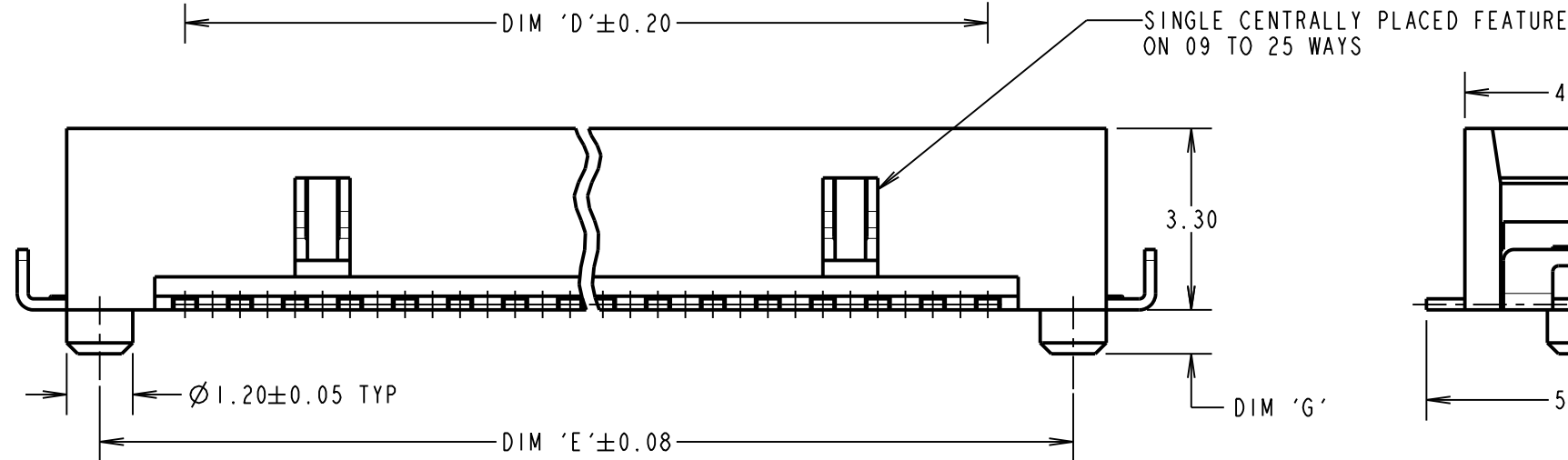
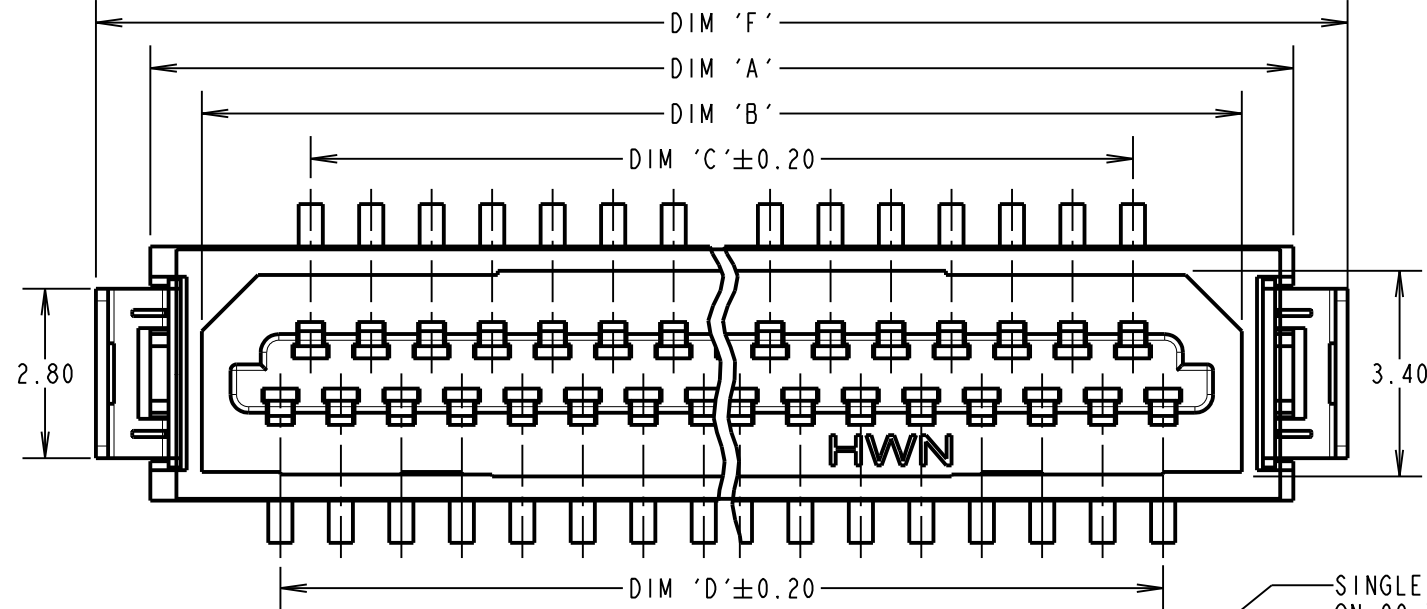

PART No.	No. OF CONTACTS	DIM 'A'	DIM 'B'	DIM 'C'	DIM 'D'	DIM 'E'	DIM 'F'	DIM 'G'	DIM 'H'	NOTE 3
M40-6000946	9	8.30	6.60	3.00	4.00	7.10	10.10	1.00	1.84 ^{+0.10} -0.00	0.1 MAX
M40-6001546	15	11.30	9.60	6.00	7.00	10.10	13.10			
M40-6002146	21	14.30	12.60	9.00	10.00	13.10	16.10			
M40-6002546	25	16.30	14.60	11.00	12.00	15.10	18.10	0.80	3.00 ^{+0.00} -0.10	0.15 MAX
M40-6003146	31	19.30	17.60	14.00	15.00	18.10	21.10			
M40-6004146	41	24.30	22.60	19.00	20.00	23.10	26.10			
M40-6005146	51	29.30	27.60	24.00	25.00	28.10	31.10			

SPECIFICATIONS:

MATERIAL:

MOULDING = LCP, NATURAL, UL94V-0

CONTACTS = PHOSPHOR BRONZE

RETAINERS = BRASS

FINISH = 2.03µm MIN 100% TIN, OVER 1.27µm MIN NICKEL

ELECTRICAL:

CURRENT RATING = 0.5A

VOLTAGE RATING = 150V AC

DIELECTRIC STRENGTH = 250V AC FOR 1 MINUTE

INSULATION RESISTANCE = 500MΩ MIN

CONTACT RESISTANCE = 50mΩ MAX

MECHANICAL:

DURABILITY = 30 CYCLES MIN

ENVIRONMENTAL:

TEMPERATURE RANGE = -20°C TO +125°C

PACKING:

TUBE

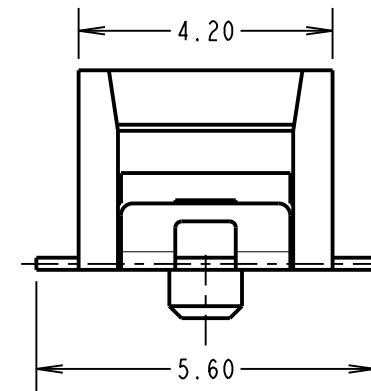

RECOMMENDED PAD LAYOUT

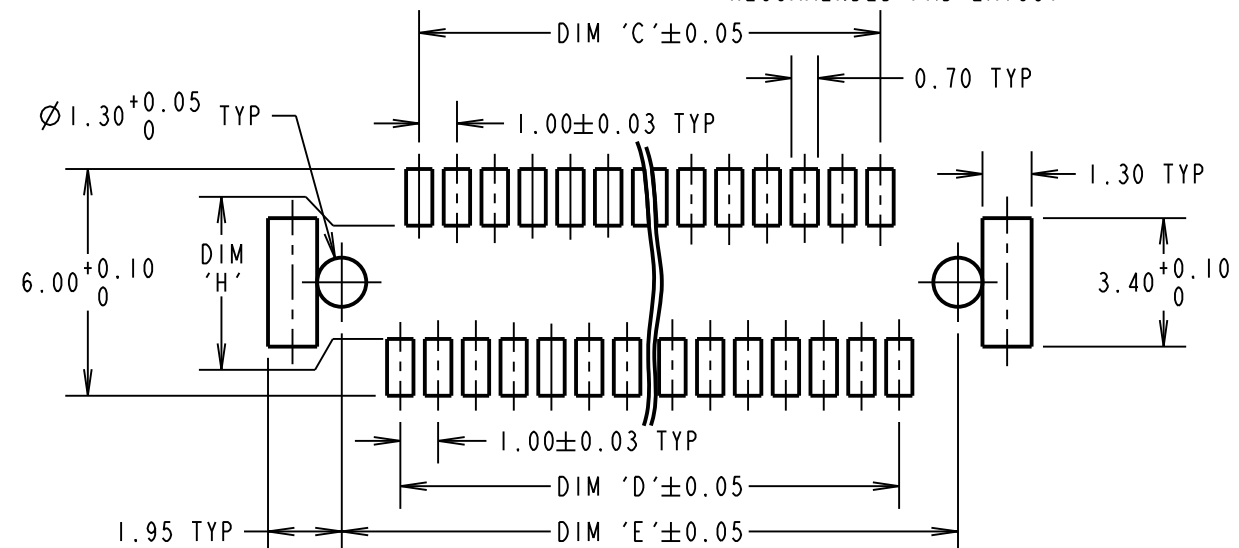

NOTES:

- MATES WITH M40-620XX46 TO GIVE 4.3mm BOARD TO BOARD HEIGHT.
- ALL TOLERANCES ARE ±0.25 UNLESS OTHERWISE STATED.
- COPLANARITY - ALIGNMENT OF SMT TAILS AND RETAINERS MUST NOT EXCEED TOLERANCE GIVEN IN TABLE.

ORDER CODE:
M40-600XX46

No. OF CONTACTS
9, 15, 21, 25, 31,
41, 51.

FINISH:
46 = 100% TIN

HARWIN

www.harwin.com
technical@harwin.com

THIS DRAWING AND ANY INFORMATION OR DESCRIPTIVE MATTER SET OUT HEREON ARE CONFIDENTIAL AND COPYRIGHT PROPERTY OF THE HARWIN GROUP AND MUST NOT BE DISCLOSED, LOANED, COPIED OR USED FOR MANUFACTURING, TENDERING OR FOR ANY OTHER PURPOSE WITHOUT THEIR WRITTEN PERMISSION.

TOLERANCES
X = ±1mm
X.X = ±0.50mm
X.XX = ±0.10mm
X.XXX = ±0.01mm
ANGLES = ±5°
UNLESS STATED

MATERIAL:
SEE ABOVE

FINISH:
SEE ABOVE

S/AREA:
mm²

TITLE:
1.00mm PITCH SMT
PLUG CONNECTOR

DRAWING NUMBER:
M40-600XX46

SHT 2 OF 2

MGP	15	14.08.18	21443
NAME	ISS.	DATE	C/NOTE
APPROVED: MGP			
CHECKED: RP			
DRAWN: R.ADDE			
CUSTOMER REF.:			
ASSEMBLY DRG:			