

2x04~2x08

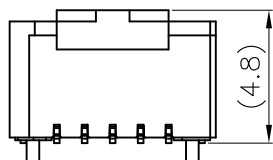
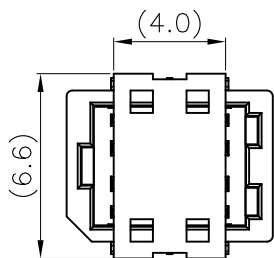

**OBSOLETE:**  
**Loose**  
**(without R)**

#NOTE: REMOVE R FOR LOOSE BAG PACKING

ORDER CODE M40-302 XX 46R	WITH R: REEL PACKING
NO. OF WAYS	WITHOUT R: LOOSE BAG PACKING (10 PCS PER STRIP, 10 STRIPS PER BAG)

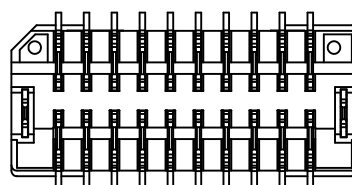
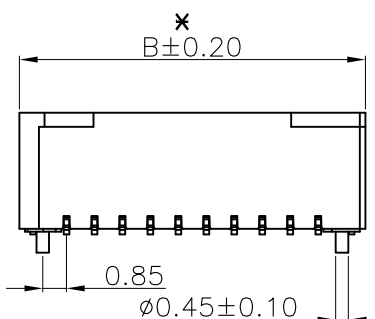
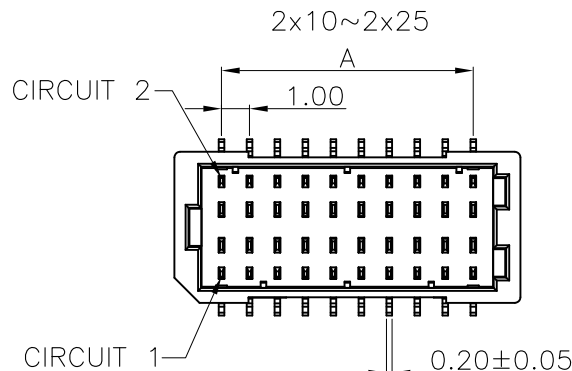

2x04~2x08

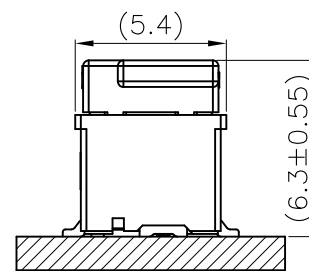
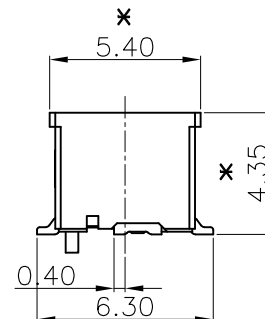
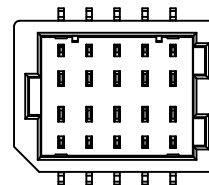

Mating Condition (REF.)

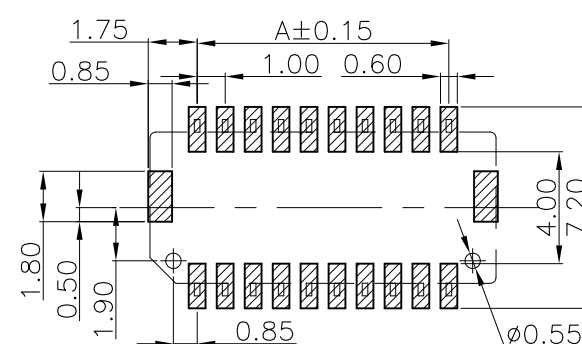

TOLERANCE: ±0.05  
RECOMMENDED P.C.B. Layout  
TOP VIEW

Pin	Dim.(mm)		Order Code
	A	B	
2X05	4.00	7.30	M40-3020546
2X06	5.00	8.30	M40-3020646
2X07	6.00	9.30	M40-3020746
2X08	7.00	10.30	M40-3020846
2X10	9.00	12.30	M40-3021046
2X12	11.00	14.30	M40-3021246
2X15	14.00	17.30	M40-3021546
2X20	19.00	22.30	M40-3022046
2X25	24.00	27.30	M40-3022546

Leo	9	22.05.19	A541
Leo	8	08.02.18	A532
Allan	7	28.07.09	A225
Allan	6	06.10.08	A166
Allan	5	25.06.08	A136
Allan	4	25.06.08	A132
Allan	3	19.06.08	A130
Allan	2	29.06.07	A056
Allan	1	01.08.06	--

**SPECIFICATIONS:**  
**MATERIAL:**  
INSULATION: LCP, UL94V-0 (HALOGEN FREE); COLOR: CREAM  
CONTACT: COPPER ALLOY, t=0.20mm  
**FINISH:**  
MATTE-TIN PLATED OVER NICKEL  
**ELECTRICAL:**  
CURRENT RATING: 1A AC/DC  
WORKING VOLTAGE: 50V AC/DC  
WITHSTANDING VOLTAGE: 500V AC/MINUTE  
CONTACT RESISTANCE: 20 mΩ MAX.  
INSULATION RESISTANCE: 100 MΩ MIN.  
**ENVIRONMENTAL:**  
TEMPERATURE RANGE: -25°C TO +85°C

**NOTE:**  
ALL DIMENSIONS AND NOTES MARKED \* ARE CRITICAL AND MUST BE CHECKED IN ACCORDANCE WITH QUALITY DOC. QI-02A

NAME	ISS.	DATE	C/NOTE
APPROVED:		B.Lim	
CHECKED:		D.P	
DRAWN:		Leo	
CUSTOMER REF.:			
ASSEMBLY DRG.:			

**HARWIN**

HARWIN USA  
TEL: 603 893 5376  
FAX: 603 893 5396  
mis@harwin.com

HARWIN Europe (UK)  
TEL: 023 9231 4545  
FAX: 023 9231 4590  
mis@harwin.co.uk

HARWIN Asia  
TEL: +65 6 779 4909  
FAX: +65 6 779 3868  
mis@harwin.com.sg

THIS DRAWING AND ANY INFORMATION OR DESCRIPTIVE MATTER SET OUT HEREON ARE CONFIDENTIAL AND COPYRIGHT PROPERTY OF THE HARWIN GROUP AND MUST NOT BE DISCLOSED, LOANED, COPIED OR USED FOR MANUFACTURING, TENDERING OR FOR ANY OTHER PURPOSE WITHOUT THEIR WRITTEN PERMISSION.

**TOLERANCES**  
X. = ±1mm  
X.X = ±0.25mm  
X.XX = ±0.15mm  
X.XXX = ±0.08mm  
ANGLES = ±5°  
UNLESS STATED

**MATERIAL:**  
SEE NOTES  
**FINISH:**  
SEE NOTES  
**S/AREA:** mm<sup>2</sup>

**TITLE:**  
WAFER 1.00mm DIL SMT TYPE  
**DRAWING NUMBER:**  
M40-302 XX 46 X  
SHT 1 OF 2

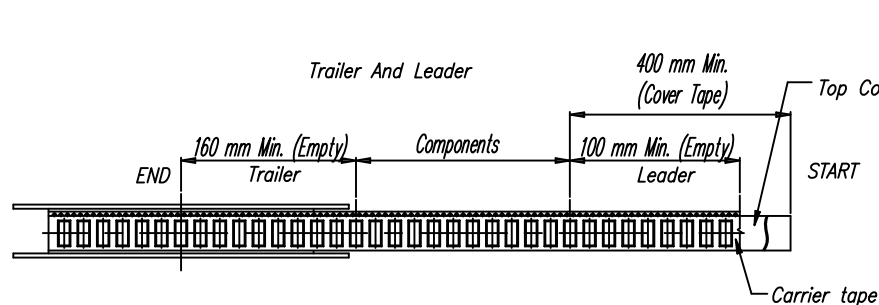

PEEL OFF DIRECTION

PEELING ANGLE  
165°~180°

PULL OUT DIRECTION

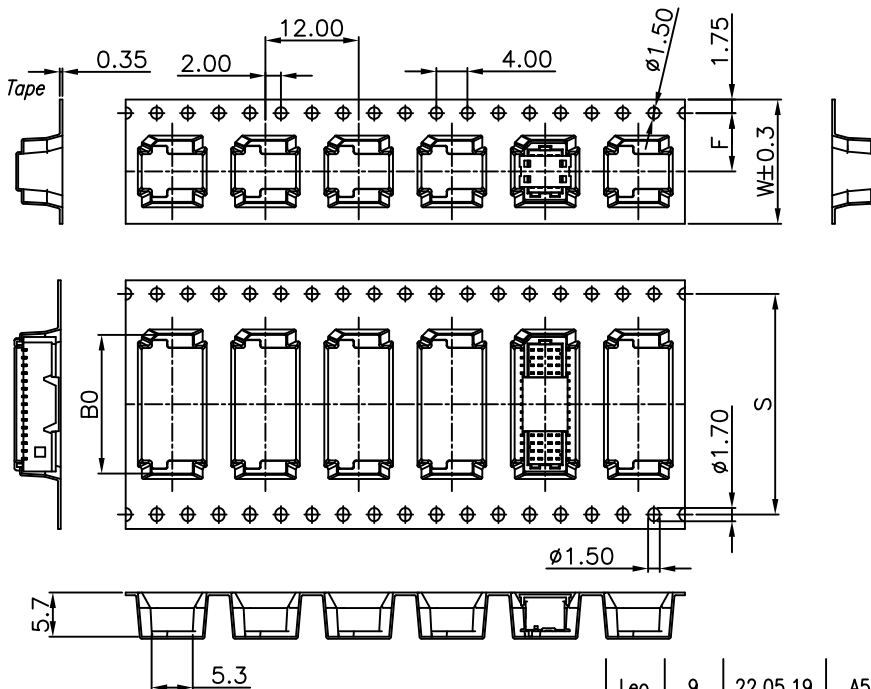
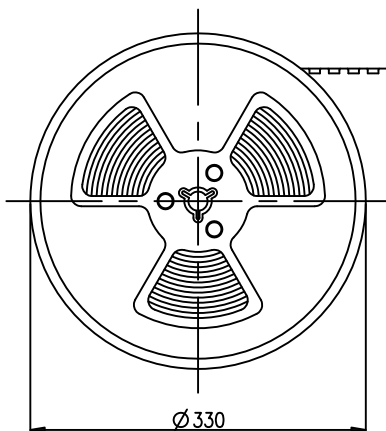
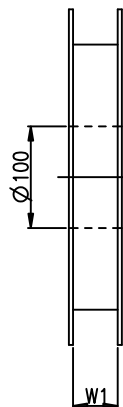

PIN	B0	F	S	W	W1	PIN	B0	F	S	W	W1
2x04	6.85	7.50	--	16.00	16.50	2x10	12.85	11.50	--	24.00	24.50
2x05	7.85	7.50	--	16.00	16.50	2x11	13.85	11.50	--	24.00	24.50
2x06	8.85	7.50	--	16.00	16.50	2x12	14.85	11.50	--	24.00	24.50
2x07	9.85	11.50	--	24.00	24.50	2x15	17.85	14.20	28.40	32.00	32.50
2x08	10.85	11.50	--	24.00	24.50	2x20	22.85	20.20	40.40	44.00	44.50

- 10 SPROCKET HOLE PITCH CUMULATIVE TOLERANCE  $\pm 0.20$
- CARRIER CAMBER IS WITHIN 1 mm IN 250 mm
- THE TOTAL TEARING CONTROL RANGE OF TOP COVER TAPE IS 10~130g, REFERENCE SPEC: EIA-481-D
- PEELING SPEED: 300mm/MINUTES, REFERENCE SPEC: EIA-481-D
- MATERIAL: TRANSPARENT CONDUCTIVE POLYSTYRENE ALLOY.(UP-5000)
- ALL DIMENSIONS MEET EIA-481-D REQUIREMENTS
- THICKNESS :  $0.40 \pm 0.05$ mm
- COMPONENT LOAD PER 13" REEL : 1000 PCS

NOTE: ALL DIMENSIONS AND NOTES MARKED \* ARE CRITICAL AND MUST BE CHECKED IN ACCORDANCE WITH QUALITY DOC. QI-02A

Leo	9	22.05.19	A541
Leo	8	08.02.18	A532
Allan	7	28.07.09	A225
Allan	6	06.10.08	A166
Allan	5	25.06.08	A136
Allan	4	25.06.08	A132
Allan	3	19.06.08	A130
Allan	2	29.06.07	A056
Allan	1	01.08.06	--

NAME	ISS.	DATE	C/NOTE
------	------	------	--------

APPROVED: B.Lim

CHECKED: D.P

DRAWN: Leo

CUSTOMER REF.:

ASSEMBLY DRG:

# HARWIN

HARWIN USA  
TEL: 603 893 5376  
FAX: 603 893 5396  
mis@harwin.com

HARWIN Europe (UK)  
TEL: 023 9231 4545  
FAX: 023 9231 4590  
mis@harwin.co.uk

HARWIN Asia  
TEL: +65 6 779 4909  
FAX: +65 6 779 3868  
mis@harwin.com.sg

THIS DRAWING AND ANY INFORMATION OR DESCRIPTIVE MATTER SET OUT HEREON ARE CONFIDENTIAL AND COPYRIGHT PROPERTY OF THE HARWIN GROUP AND MUST NOT BE DISCLOSED, LOANED, COPIED OR USED FOR MANUFACTURING, TENDERING OR FOR ANY OTHER PURPOSE WITHOUT THEIR WRITTEN PERMISSION.

TOLERANCES  
X. =  $\pm 1$ mm  
X.X =  $\pm 0.25$ mm  
X.XX =  $\pm 0.15$ mm  
X.XXX =  $\pm 0.08$ mm  
ANGLES =  $\pm 5^\circ$   
UNLESS STATED

MATERIAL: SEE NOTES  
FINISH: SEE NOTES  
S/AREA: mm<sup>2</sup>

TITLE: WAFER 1.00mm DIL SMT TYPE

DRAWING NUMBER: M40-302 XX 46 X

SHT  
2  
OF  
2