

CUSTOMER INFORMATION SHEET

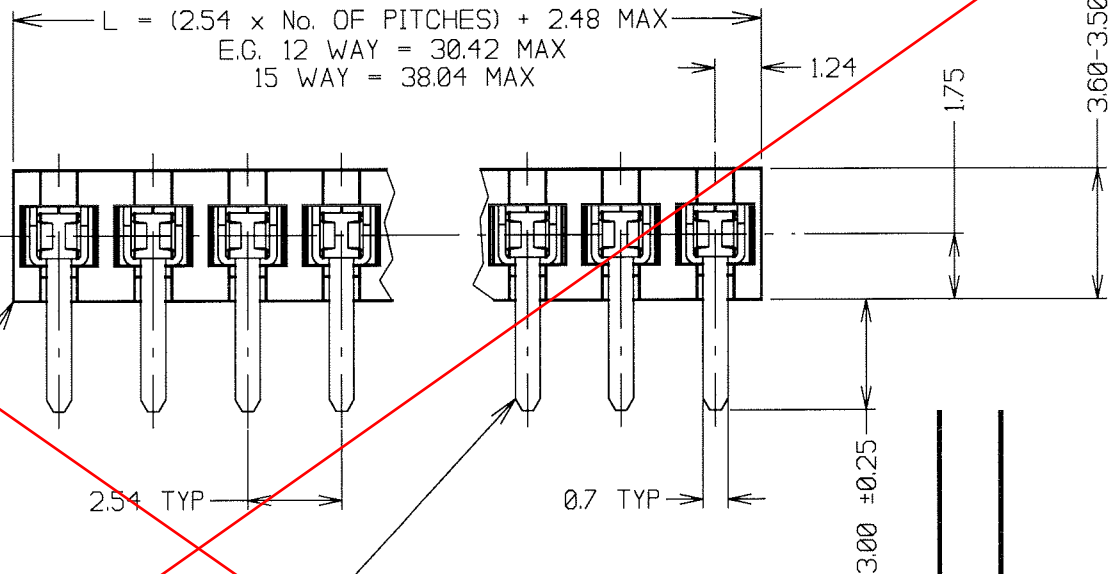
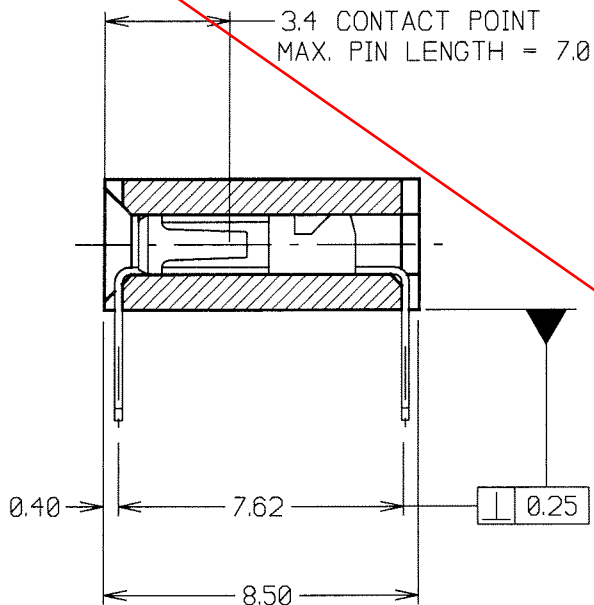

MOULDING:
MATERIAL = GLASS-FILLED
POLYESTER UL94V-0

SOCKETS:
MATERIAL = PHOSPHOR BRONZE
FINISH =
06 - 90/10 TIN/LEAD
22 - GOLD OVER NICKEL ON CONTACT FACE,
90/10 TIN/LEAD ON P.C. TAILS
27 - 0.8µ GOLD OVER NICKEL ON CONTACT FACE,
90/10 TIN/LEAD ON P.C. TAILS

13	17.11.95	3104
12	29.09.95	3049
3	13.07.93	2334
2	17.03.93	2223
1	24.05.91	----

ISS.	DATE	C/N
------	------	-----

APPROVED:

CHECKED:

DRAWN: W. BOURNE

CUSTOMER REF.

ASSEMBLY DRG:

ORDER CODE: **M20-989XXXX**

No. OF WAYS _____
02 TO 36

FINISH:
06 = TIN/LEAD
22 = SELECTIVE GOLD/TIN-LEAD
27 = 0.8µ SELECTIVE GOLD/TIN-LEAD

OBSOLETE

HARWIN

HARWIN INC
U.S.A.

TEL: (812) 285 0055
FAX: (812) 285 0056

HARWIN PLC
U.K.

TEL: (01705) 370451
FAX: (01705) 324010

HARWIN PTE
SINGAPORE

TEL: 7794909
FAX: 7793868

TOLERANCES

- X. = ±1mm
- X.X = ±0.25mm
- X.XX = ±0.10mm
- X.XXX = ±0.01mm
- ANGLES = ±1°
- UNLESS STATED

MATERIAL:

SEE ABOVE

FINISH: SEE ABOVE

S/AREA:

mm²

TITLE:

P.C. SOCKET ASSEMBLY
(SINGLE ROW - HORIZONTAL)

DRAWING NUMBER:

M20-989XXXX

SHT
2
OF
2