

Gecko Connectors Specifications

Materials

Mouldings:	Glass-filled High Temperature Thermoplastic UL94V-0
Female contacts:	Beryllium Copper
Male contacts	
PCT/SMT:	Phosphor Bronze
Crimp:	Brass
Finish:	0.2 – 0.3µm (8 – 12µ") Gold, over 1.5 – 2.0µm (60 – 80µ") Nickel
Screw-Loks:	Stainless Steel
Latches:	Copper Alloy

Electrical

Current	
Individual contacts in isolation:	2.8A max (At 25°C)
All contacts simultaneously:	2.0A max (At 25°C)
Working voltage	
At sea level 1006 mbar:	450V DC or AC peak
At altitude 44 mbar:	250V DC or AC peak
Voltage proof	
At sea level 1013 mbar:	600V DC or AC peak
Contact resistance	
Initial:	20mΩ max
After conditioning:	25mΩ max
Insulation resistance	
Initial:	10GΩ min at 500V DC
After conditioning:	>1GΩ min at 500V DC

Mechanical

Contact durability:	1000 operations
Mating forces (per contact pair)	
Insertion force:	2.8N max
Withdrawal force:	0.2N min
Contact retention in moulding:	6N min

Environmental

Environmental classification:	65/150/56 days at 93% RH
Operating temperature:	-65°C to +150°C
*Vibration sensitivity:	10Hz to 2000Hz, 1.5mm, 198mm/s ² (20G) duration 6 hours
*Bump severity:	390m/s ² (40G), 4000 ±10 bumps
*Shock severity:	981m/s ² (100G) for 6ms in Z axis 490m/s ² (50G) for 11ms in X & Y axes
*Acceleration severity:	490m/s ² (50G)

* Tested with latched connectors.

Pin Numbering

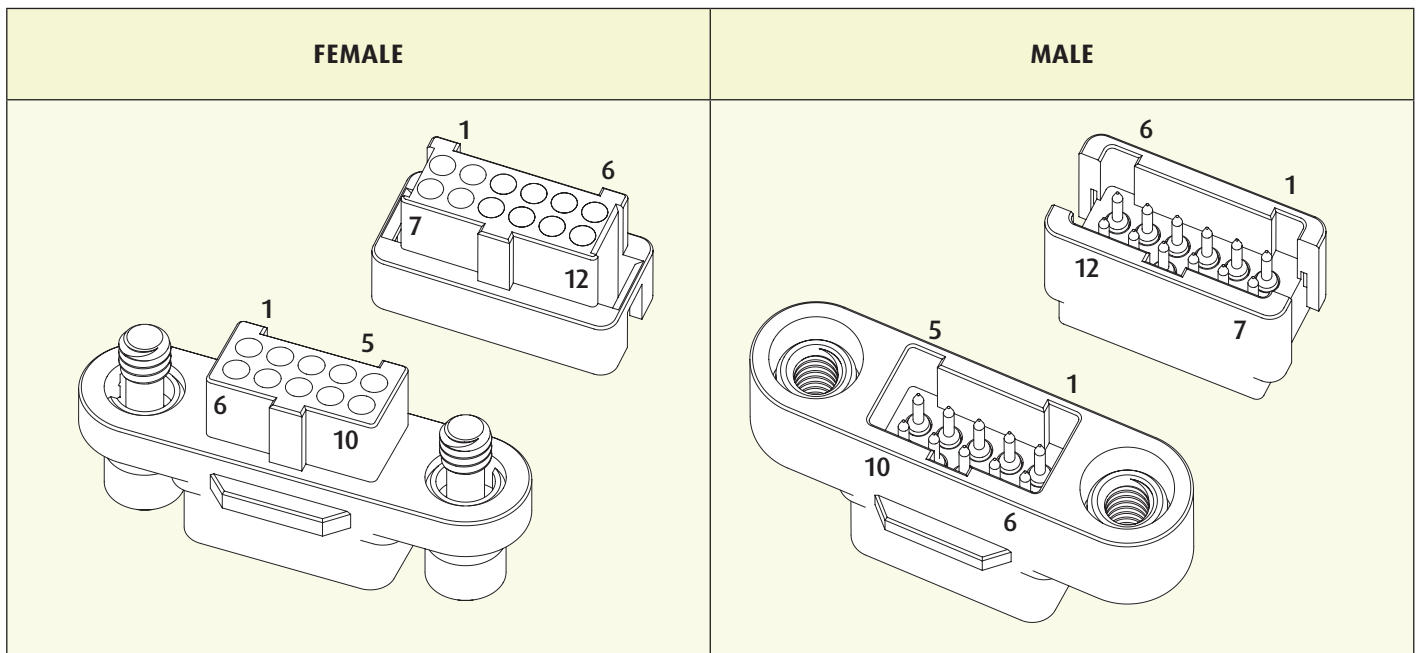

Patent Published