

Customer Information Sheet

IF IN DOUBT - ASK

©

NOT TO SCALE

THIRD ANGLE PROJECTION

ALL DIMENSIONS IN mm

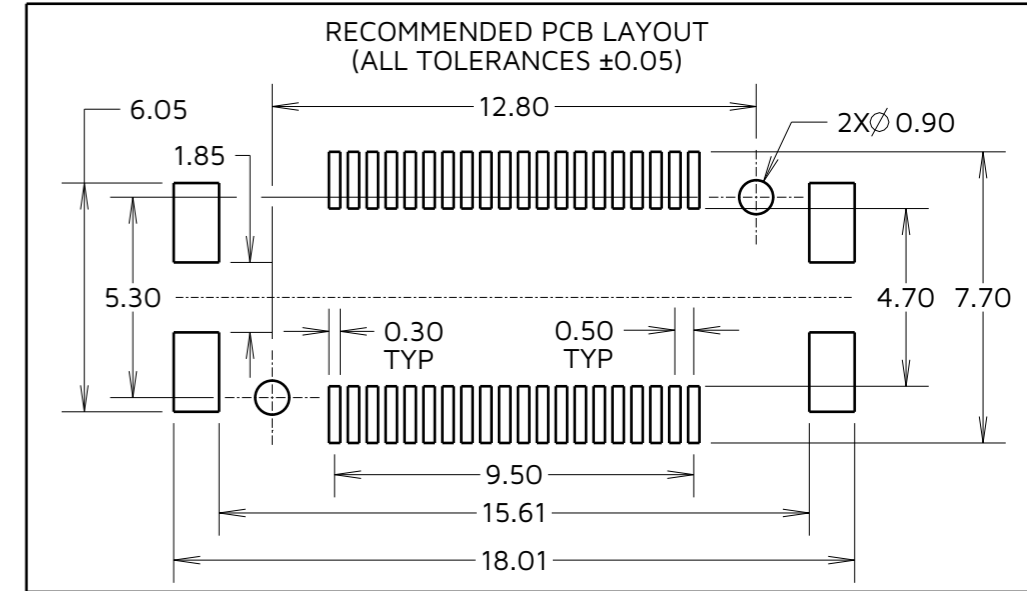
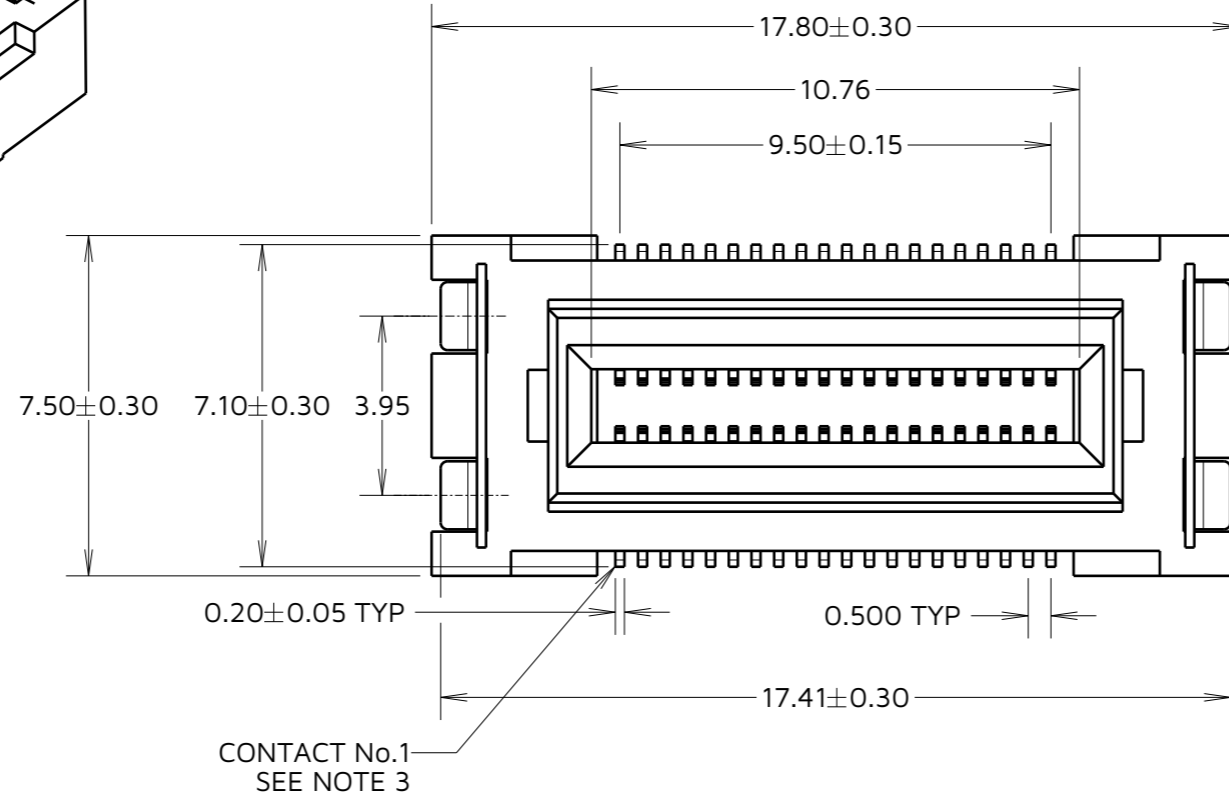
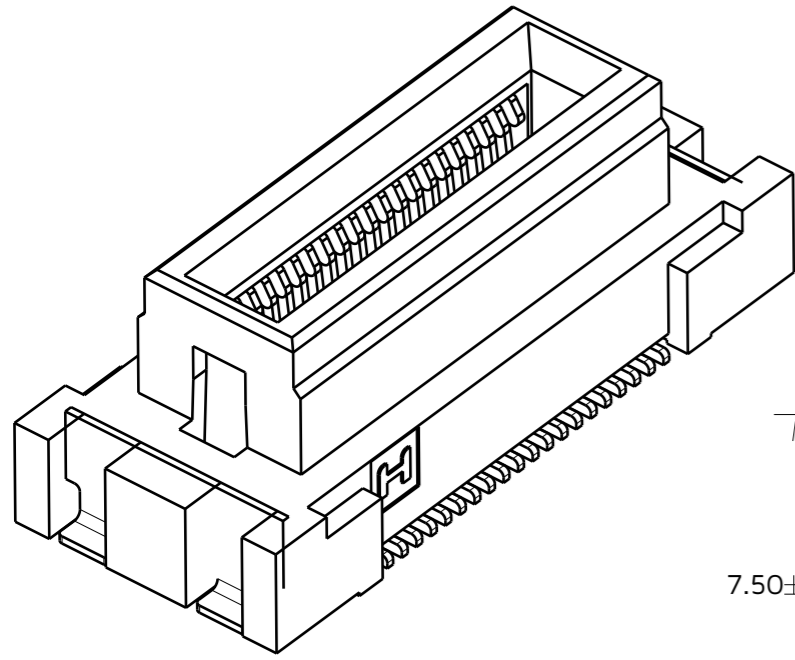

DETAIL 'B'

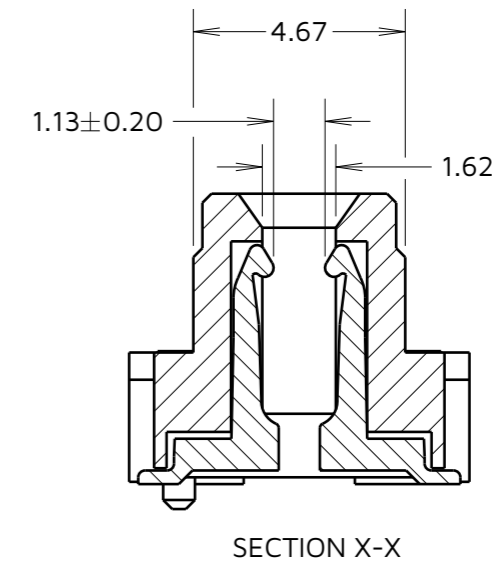
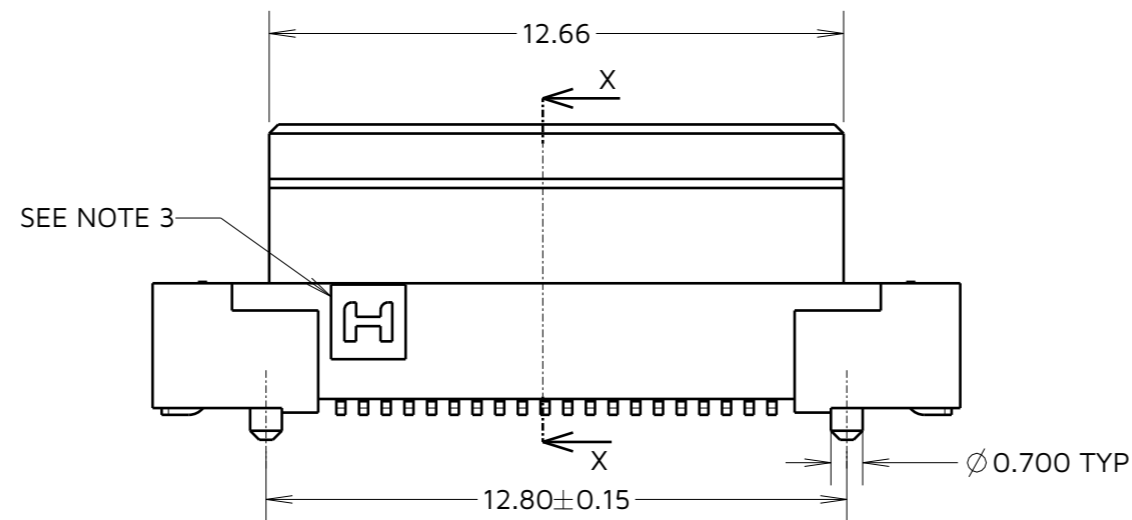
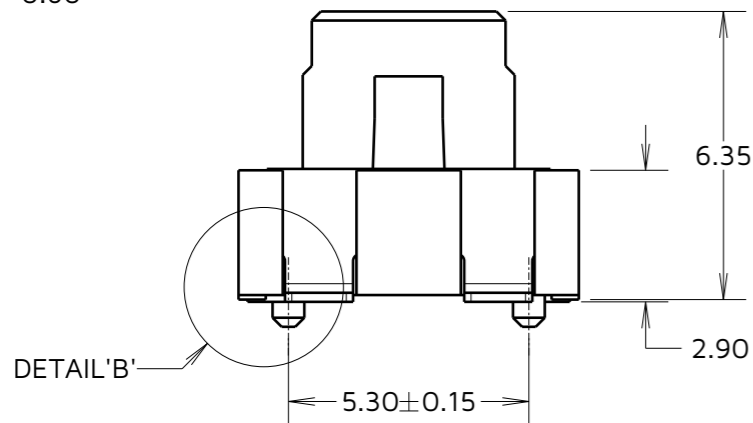
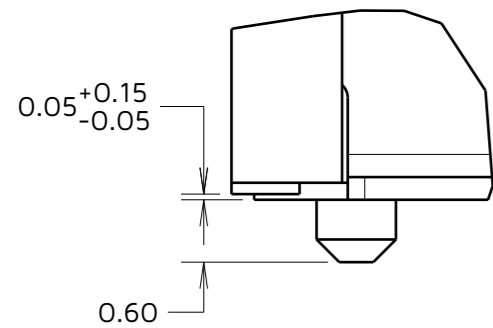

- NOTES:
- SEE COMPONENT SPECIFICATION C057XX (LATEST ISSUE) FOR COMPLETE CONNECTOR SPECIFICATIONS.
 - SEE SHEET 4 FOR TAPE & REEL DETAILS.
 - HARWIN LOGO SHOWN IN THIS ORIENTATION FOR REFERENCE ONLY. LOGO IS UNRELATED TO CONTACT No.1, AS CONTACT No.1 WILL ALWAYS BE THIS POSITION.

HARWIN

www.harwin.com

TOLERANCES
X = ±1mm
X.X = ±0.50mm
X.XX = ±0.20mm
X.XXX = ±0.01mm
ANGLES = ±5°
UNLESS STATED

THIS DRAWING AND ANY INFORMATION OR DESCRIPTIVE MATTER SET OUT HEREON ARE CONFIDENTIAL AND COPYRIGHT PROPERTY OF THE HARWIN GROUP AND MUST NOT BE DISCLOSED, LOANED, COPIED OR USED FOR MANUFACTURING, TENDERING OR FOR ANY OTHER PURPOSE WITHOUT THEIR WRITTEN PERMISSION.

MATERIAL:
SEE NOTE 1

TITLE:
0.5mm PITCH FEMALE FLECTO CONNECTOR
DRAWING NUMBER:
F12-10004042R

AB	2	24.02.24	33735
NAME	ISS.	DATE	CN/CO
APPROVED: A.YEOMANS			
CHECKED: F.CHRISPINE			
DRAWN: A.BOXALL			
ASSEMBLY DRG:			

TOLERANCES	
X.=±0.35	X.°=±5.0°
X.X=±0.30	X.X°=±3.0°
X.XX=±0.20	X.XX°=±2.0°
X.XXX=±0.10	X.XXX°=±1.0°

